



Online oil analysis

ECOSENSE[®] ACTIVE PART

Operating instructions

8969216/00 EN



© All rights reserved by Maschinenfabrik Reinhausen

Dissemination and reproduction of this document and use and disclosure of its content are strictly prohibited unless expressly permitted.

Infringements will result in liability for compensation. All rights reserved in the event of the granting of patents, utility models or designs.

The product may have been altered since this document was published.

We reserve the right to change the technical data, design and scope of supply.

Generally the information provided and agreements made when processing the individual quotations and orders are binding.

The original operating instructions were written in German.

Table of contents

1	Introduction.....	6
1.1	Manufacturer.....	6
1.2	Subject to change without notice	6
1.3	Completeness.....	6
1.4	Safekeeping.....	7
1.5	Notation conventions	7
1.5.1	Hazard communication system	7
1.5.2	Information system.....	8
1.5.3	Instruction system	8
1.5.4	Typographic conventions	9
2	Safety.....	10
2.1	Appropriate use	10
2.2	Fundamental safety instructions	11
2.3	Personnel qualification.....	12
2.4	Personal protective equipment	13
3	IT security.....	15
4	Product description.....	16
4.1	Scope of delivery	17
4.2	Function description.....	17
4.3	Design/versions	18
4.4	Safety markings and nameplate	19
5	Packaging, transport and storage	20
5.1	Purpose	20
5.2	Suitability, structure and production.....	20
5.3	Markings	20
5.4	Transportation, receipt and handling of shipments.....	20
5.5	Storage of shipments.....	22

Table of contents

5.6	Further transport	22
6	Installation.....	23
6.1	Installation recommendation	24
6.2	Mounting the device.....	25
6.2.1	Preparing the transformer and ball valve	25
6.2.2	Mounting the device for online oil analysis.....	33
6.3	Electrical connection.....	45
6.3.1	Electromagnetic compatibility.....	46
6.3.2	Cable recommendation	46
6.3.3	Routing and preparing the cables	46
6.3.4	Supply voltage and protective conductor	47
6.3.5	Device grounding	48
6.3.6	SCADA connection	49
7	Commissioning.....	52
7.1	Service interface	52
7.2	Installing the MESSKO® MSET parameterization software	53
7.3	Commissioning in existing systems	54
7.4	Parameterization.....	54
7.4.1	Settings for carbon monoxide, hydrogen and moisture in oil concentrations .. 55	
7.4.2	General settings	56
7.4.3	Modbus settings	57
8	Operation.....	59
8.1	Main screen / Operating display	59
8.2	Events.....	61
9	Fault elimination	63
9.1	Display faults	63
9.2	Replace safety fuse	63

Table of contents

10	Maintenance	65
10.1	Inspection	65
10.2	Maintenance	66
10.3	Oil extraction.....	67
10.4	Device field calibration.....	68
10.4.1	Taking a sample for field calibration.....	68
10.4.2	Field calibration	69
10.5	Cleaning.....	72
11	Removal	73
11.1	Removing the device	74
12	Disposal	85
13	Technical data	86
14	Drawings	89
14.1	Maßzeichnung-ECOSENSE®ACTIVE-PART.pdf.....	90
15	Appendix	93
15.1	Data point table for Modbus RTU	93

1 Introduction

This technical document contains detailed descriptions on the safe and proper installation, connection, commissioning and monitoring of the product.

This technical document is intended solely for specially trained and authorized personnel.

1.1 Manufacturer

Maschinenfabrik Reinhausen GmbH
Falkensteinstrasse 8
93059 Regensburg
Germany

Tel.: +49 941 4090 2703

E-mail: ecosense@reinhausen.com

Internet: www.reinhausen.com

MR Reinhausen customer portal: <https://portal.reinhausen.com>

Further information on the product and copies of this technical file are available from this address if required.

1.2 Subject to change without notice

The information contained in this technical file comprises the technical specifications approved at the time of printing. Significant modifications will be included in a new edition of the technical file.

The document number and version number of this technical file are shown in the footer.

1.3 Completeness

This technical file is incomplete without the supporting documents:

- Works certification
- ECOSENSE® ACTIVE PART operating instructions
- MESSKO® MSET parameterization software operating instructions
 - Register for download in the customer portal:
<https://portal.reinhausen.com>.
 - Create your ECOSENSE® ACTIVE PART under **myEquipment > Components**.
 - Then enter the serial number under **mySelfServices > Software updates**.

1.4 Safekeeping

Keep this technical file and all supporting documents ready at hand and accessible for future use at all times.

1.5 Notation conventions

This section contains an overview of the symbols and textual emphasis used.

1.5.1 Hazard communication system

Warnings in this technical file are displayed as follows.

1.5.1.1 Warning relating to section

Warnings relating to sections refer to entire chapters or sections, sub-sections or several paragraphs within this technical document. Warnings relating to sections have the following format:

WARNING



Type of danger!

Source of the danger and its consequences.

- ▶ Action
- ▶ Action

1.5.1.2 Embedded warning information

Embedded warnings refer to a particular part within a section. These warnings apply to smaller units of information than the warnings relating to sections. Embedded warnings use the following format:

 **DANGER!** Instruction for avoiding a dangerous situation.

1 Introduction

1.5.1.3 Signal words

Depending on the product, the following signal words are used:

Signal word	Meaning
DANGER	Indicates a hazardous situation which, if not avoided, will result in death or serious injury.
WARNING	Indicates a hazardous situation which, if not avoided, could result in death or serious injury.
CAUTION	Indicates a hazardous situation which, if not avoided, could result in minor or moderate injury.
NOTICE	Indicates measures to be taken to prevent damage to property.

Table 1: Signal words in warning notices

1.5.2 Information system

Information is designed to simplify and improve understanding of particular procedures. In this technical file it is laid out as follows:



Important information.

1.5.3 Instruction system

This technical file contains single-step and multi-step instructions.

Single-step instructions

Instructions which consist of only a single process step are structured as follows:

Aim of action

✓ Requirements (optional).

► Step 1 of 1.

⇒ Result of step (optional).

⇒ Result of action (optional).

Multi-step instructions

Instructions which consist of several process steps are structured as follows:

Aim of action

✓ Requirements (optional).

1. Step 1.

⇒ Result of step (optional).

2. Step 2.

⇒ Result of step (optional).

⇒ Result of action (optional).

1.5.4 Typographic conventions

Typographic convention	Purpose	Example
UPPERCASE	Operating controls, switches	ON/OFF
[Brackets]	PC keyboard	[Ctrl] + [Alt]
Bold	Software operating controls	Press Continue button
...>...>...	Menu paths	Parameter > Control parameter
<i>Italics</i>	System messages, error messages, signals	<i>Function monitoring alarm triggered</i>
[▶ Number of pages]	Cross reference	[▶ Page 41].
<u>Dotted underscore</u>	Glossary entry, abbreviations, definitions, etc.	<u>Glossary entry</u> .

Table 2: Typographic conventions used in this technical file

2 Safety

- Read this technical file through carefully to familiarize yourself with the product.
- This technical file is a part of the product.
- Read and observe the safety instructions provided in this section in particular.
- Observe the warnings in this technical file to avoid function-related dangers.
- The product is manufactured based on state-of-the-art technology. Nevertheless, risks to life and limb for the user or impairment of the product and other material assets due to the function may arise in the event of improper use.

2.1 Appropriate use

The device is designed solely for use in electrical energy systems and facilities. It is designed to detect and report emerging, potentially harmful trends in the monitored equipment (e.g. transformer) in good time by measuring the concentration of gases and moisture in the equipment's insulating oil.

The device is not designed and is not suitable for detecting rapidly developing faults and therefore is not intended to protect the equipment from such faults (e.g. through shutdown). For this, please use safety devices that have been designed for this purpose.

If used as intended and in compliance with the requirements and conditions specified in this technical document as well as the warning notices contained in this technical document and attached to the product, the product does not pose risk of personal injury or damage to property or the environment. This applies throughout the entire service life of the product, from delivery, installation and operation to removal and disposal.

Intended use refers to the following:

- Operate the product in accordance with this technical document, the agreed-upon delivery conditions and the technical data.
- Ensure that any necessary work is only performed by qualified personnel.
- Only use the equipment included in the delivery for the intended purpose and in accordance with the specifications of this technical document.
- Observe the notices in this technical document regarding electromagnetic compatibility and the technical data.

2.2 Fundamental safety instructions

To prevent accidents, malfunctions and damage as well as unacceptable adverse effects on the environment, those responsible for transport, installation, operation, maintenance and disposal of the product or parts of the product must ensure the following:

Personal protective equipment

Loosely worn or unsuitable clothing increases the danger of becoming trapped or caught up in rotating parts and the danger of getting caught on protruding parts. This results in danger to life and limb.

- All necessary devices and personal protective equipment required for the specific task, such as a hard hat, safety footwear, etc. must be worn. Observe the "Personal protective equipment" [► Section 2.4, Page 13] section.
- Never wear damaged personal protective equipment.
- Never wear rings, necklaces or other jewelry.
- If you have long hair, wear a hairnet.

Work area

Untidy and poorly lit work areas can lead to accidents.

- Keep the work area clean and tidy.
- Make sure that the work area is well lit.
- Observe the applicable laws for accident prevention in the relevant country.

Explosion protection

Highly flammable or explosive gases, vapors and dusts can cause serious explosions and fire.

- Do not install or operate the product in areas where a risk of explosion is present.

2 Safety

Safety markings

Warning signs and safety information plates are safety markings on the product. They are an important aspect of the safety concept. Safety markings are depicted and described in the chapter "Product description".

- Observe all safety markings on the product.
- Make sure all safety markings on the product remain intact and legible.
- Replace safety markings that are damaged or missing.

Ambient conditions

To ensure reliable and safe operation, the product must only be operated under the ambient conditions specified in the technical data.

- Observe the specified operating conditions and requirements for the installation location.

Modifications and conversions

Unauthorized or inappropriate changes to the product may lead to personal injury, material damage and operational faults.

- Only modify the product after consultation with the manufacturer.

Spare parts

Spare parts not approved by the manufacturer may lead to physical injury and damage to the product.

- Only use spare parts approved by the manufacturer.
- Contact the manufacturer.

Working during operation

You must only operate the product when it is in a sound operational condition. Otherwise it poses a danger to life and limb.

- Regularly check the operational reliability of safety equipment.
- Perform the inspection tasks described in this technical document regularly.

2.3 Personnel qualification

The person responsible for assembly, commissioning, operation, maintenance and inspection must ensure that the personnel are sufficiently qualified.

Electrically skilled person

The electrically skilled person has a technical qualification and therefore has the required knowledge and experience, and is also conversant with the applicable standards and regulations. The electrically skilled person is also proficient in the following:

- Can identify potential dangers independently and is able to avoid them.
- Is able to perform work on electrical systems.
- Is specially trained for the working environment in which (s)he works.
- Must satisfy the requirements of the applicable statutory regulations for accident prevention.

Electrically trained persons

An electrically trained person receives instruction and guidance from an electrically skilled person in relation to the tasks undertaken and the potential dangers in the event of inappropriate handling as well as the protective devices and safety measures. The electrically trained person works exclusively under the guidance and supervision of an electrically skilled person.

Operator

The operator uses and operates the product in line with this technical document. The operating company provides the operator with instruction and training on the specific tasks and the associated dangers arising from improper handling.

Technical Service

We strongly recommend that you only have maintenance, repair and retrofitting work carried out by qualified Technical Service employees.

2.4 Personal protective equipment

Personal protective equipment must be worn during work to minimize risks to health.

- Always wear the personal protective equipment required for the job at hand.
- Never wear damaged personal protective equipment.
- Observe information about personal protective equipment provided in the work area.

2 Safety

Protective clothing	Close-fitting work clothing with a low tearing strength, with tight sleeves and with no protruding parts. It mainly serves to protect the wearer against being caught by moving machine parts.
Safety shoes	To protect against falling heavy objects and slipping on slippery surfaces.
Safety glasses	To protect the eyes from flying parts and splashing liquids.
Visor	To protect the face from flying parts and splashing liquids or other dangerous substances.
Hard hat	To protect from falling and flying parts and materials.
Hearing protection	To protect against hearing damage.
Protective gloves	To protect against mechanical, thermal and electrical hazards.

Table 3: Personal protective equipment

Observe the following recommendations to operate the product safely.

- Ensure that only authorized personnel have access to the device.
- Only use the device within an ESP (electronic security perimeter).
- Ensure that the device is only operated by trained personnel who are familiar with IT security.
- With this product, the protocol interface (Modbus RTU) only has read access. Changing parameters or data via this is not possible.
- Access to the parameterization via the MESSKO® MSET parameterization software can be protected through the use of passwords. Change the passwords regularly.



Observe the information of access rights, user levels and password settings in the MESSKO® MSET parameterization software operating instructions.

4 Product description

The detection of dissolved gases in transformer oil is generally considered to be the first indication of emerging faults in transformers. Several international standards highlight the relevance of this examination method, including the IEEE Std C57.104™-2008, IEC 60422, IEC 60567 and IEC 60599 standards.

The Dissolved Gas Analysis (DGA) method is fast, low-cost and possible without disconnecting the transformer. The composition of the gases provides initial key information on fault events such as partial discharges, overheating, arcs and overload. This knowledge enables sound risk assessment and the early initiation of measures for corrective action.

The standards listed above recommend that oil samples be taken at regular intervals and that they be analyzed by a laboratory. In addition to a DGA, further examinations are usually performed, such as the determination of the moisture in oil, the dielectric strength and the turbidity.

Two gases in particular are to be considered during a DGA: hydrogen (H₂) and carbon monoxide (CO), since these are generated in virtually all occurring faults. The occurrence of hydrogen is an indication of electrical faults in the transformer, and carbon monoxide is generated during the decomposition of the paper insulation, which is caused by overheating.

Increased moisture in the oil significantly reduces the dielectric strength of the insulating oil and also promotes paper decomposition; thus, monitoring the water content (H₂O) in the oil provides essential additional information for the assessment of risks.

Continuous online monitoring of these two gases and the moisture enables early detection of emerging, potentially harmful trends. As soon as defined warning thresholds are exceeded, further analyses can be carried out and countermeasures can be taken at an early stage. The costs for quickly implemented measures are generally much lower than those implemented at a later date, and especially after a failure of the transformer with the resulting consequential costs.

The online DGA device was developed precisely for this purpose. It continuously monitors the gas concentrations of hydrogen and carbon monoxide as well as the moisture in oil, and issues warning or alarm messages if defined gas or moisture concentrations are exceeded or if the rates of increase are too high.

This chapter contains an overview of the design and function of the product.

Overview of ECOSENSE® ACTIVE PART measured variables:

- Hydrogen (H₂) fault gas
- Carbon monoxide (CO) fault gas
- Moisture in oil content
- Oil temperature.

4.1 Scope of delivery

- ECOSENSE® ACTIVE PART
- Operating instructions and works certification
- Ball valve with mounting flange, safety chain and dummy plug
- Chain connector for safety chain
- USB connection cable for connecting a computer to the device
- 5-pole plug for assembling an RS485 connection cable (Modbus RTU)
- Oil extraction adapter

4.2 Function description

The measuring head of the device is positioned in the transformer insulating oil. There is often a large distance between the measuring head and the origin of the gases. It is therefore important for the early detection of gases that the oil at the installation position is in motion, either due to natural convection or due to artificially generated oil circulation. Observe the additional information regarding this in the chapter "Installation recommendations".

The gases dissolved in the oil are dissolved out via a capillary membrane in the device measuring head. Sensors for hydrogen and carbon monoxide convert the concentrations of gas present into electrical signals. A gold coating prevents unwanted chemical reactions that could distort the measured results.

The device controller converts the electrical signals into gas concentration values in the unit ppm (parts per million). To improve the measurement results under different operating conditions, factors such as the oil temperature and ambient temperature as well as the flow velocity of the oil at the sensor head are taken into account.

In addition, the device is equipped with a sensor for measuring the level of moisture in the oil. This measurement is also taken at the measuring head directly in the oil.

4 Product description

The measured values determined are stored in the internal device database and displayed on the display. The current and historical measured data can be called up and analyzed further with the MESSKO® MSET parameterization software.

The device can be connected with a SCADA system via the Modbus interface.

4.3 Design/versions

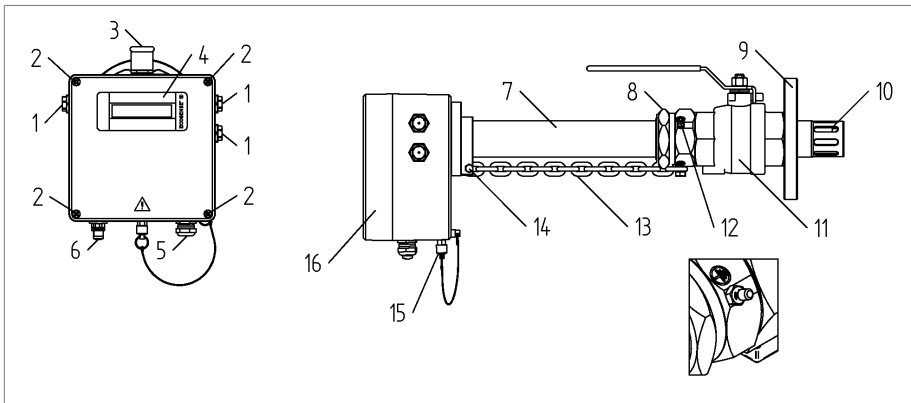

Figure 1: ECOSENSE® ACTIVE PART

Measurement components H₂, CO, moisture in oil and oil temperature (for mineral oils)

1 Ventilation	2 Housing cover screw connection
3 Ball valve locking lever	4 Display
5 Supply voltage cable screw connection (M20x1.5)	6 Interface (5-pole) for service PC and Modbus RTU communication
7 Measuring pipe: 507 mm	8 Ball valve clamp connection
9 Mounting flange any gasket: DN50 PN16 and DN80 PN16	10 Measuring head
11 Ball valve	12 Grounding screw
13 Safety chain	14 Fixing screw for safety chain
15 Connection for venting and taking samples	16 Housing cover

4 Product description

4.4 Safety markings and nameplate

The following safety markings are used on the product:

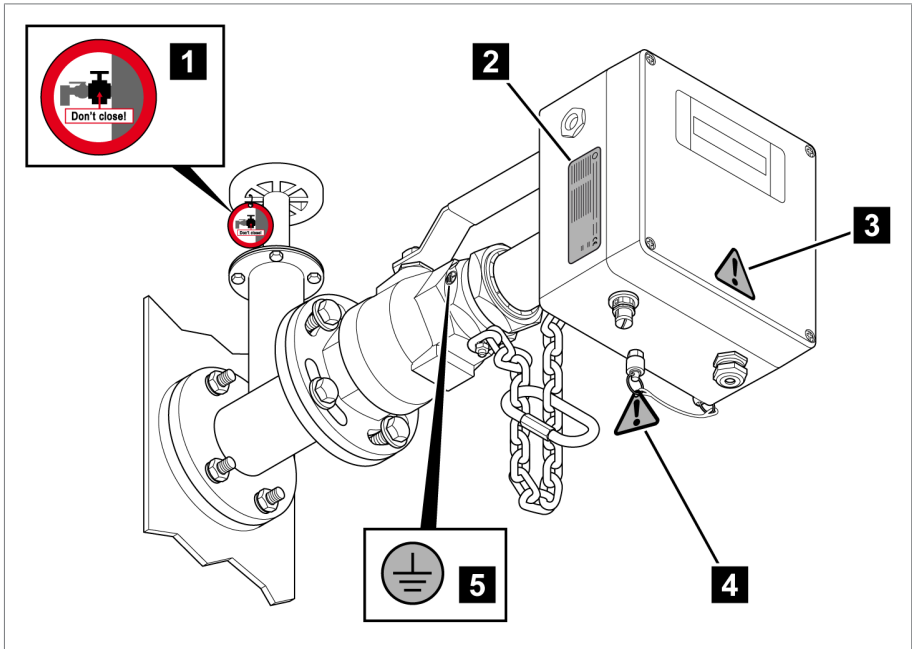

Figure 2: Safety markings and nameplate

1 Description

2 Warning sign "Do not close!" on the slide valve

3 Nameplate

4 Observe the documentation

5 Observe the documentation: See the note about the oil extraction adapter in the chapter "Mounting the device for online oil analysis" [► Section 6.2.2, Page 33]

Ground connection on the ball valve

5 Packaging, transport and storage

5.1 Purpose

The packaging is designed to protect the packaged product during transport, loading, unloading and during periods of storage in such a way that no detrimental changes occur. The packaging must protect the goods against permitted transport stresses such as vibration, knocks and moisture (rain, snow, condensation).

The packaging also prevents the packaged goods from moving impermissibly within the packaging.

5.2 Suitability, structure and production

The goods are packaged in a sturdy cardboard box. This ensures that the shipment is secure when in the intended transportation position and that none of its parts touch the loading surface of the means of transport or touch the ground after unloading.

Inlays inside the box stabilize the goods, preventing prohibited changes in position, and protecting them from vibration.

5.3 Markings

The packaging bears a signature with instructions for safe transport and correct storage. The following symbols apply to the shipment of non-hazardous goods. Adherence to these symbols is mandatory.



Protect against moisture



Top



Fragile



Attach lifting gear here



Center of mass

Table 4: Shipping pictograms

5.4 Transportation, receipt and handling of shipments

In addition to vibrations, jolts must also be expected during transportation. In order to prevent possible damage, avoid dropping, tipping, knocking over and colliding with the product.

Should the packaging tip over or fall, damage is to be expected regardless of the weight.

5 Packaging, transport and storage

Every delivered shipment must be checked for the following by the recipient before acceptance (acknowledgment of receipt):

- Completeness based on the delivery slip
- External damage of any type.

The checks must take place after unloading when the cartons or transport container can be accessed from all sides.

Visible damage

If external transport damage is found upon receipt of the shipment, proceed as follows:

- Immediately record the transport damage found in the shipping documents and have this countersigned by the carrier.
- In the event of severe damage, total loss or high damage costs, immediately notify the manufacturer's sales department and the relevant insurance company.
- After identifying damage, do not modify the condition of the shipment further and retain the packaging material until an inspection decision has been made by the transport company or the insurance company.
- Record the details of the damage immediately on site together with the carrier involved. This is essential for any claim for damages.
- If possible, photograph damage to packaging and packaged goods. This also applies to signs of corrosion on the packaged goods due to moisture inside the packaging (rain, snow, condensation).
- Be absolutely sure to also check the sealed packaging.

Hidden damage

When damage is not determined until unpacking after receipt of the shipment (hidden damage), proceed as follows:

- Make the party responsible for the damage liable as soon as possible by telephone and in writing, and prepare a damage report.
- Observe the time periods applicable to such actions in the respective country. Inquire about these in good time.

With hidden damage, it is very hard to make the transportation company (or other responsible party) liable. Any insurance claims for such damage can only be successful if relevant provisions are expressly included in the insurance terms and conditions.

5 Packaging, transport and storage

5.5 Storage of shipments

When selecting and setting up the storage location, ensure the following:

- Store the product and accessories in the original packaging until installation.
- Protect stored goods against moisture (rain, flooding, water from melting snow and ice), dirt, pests such as rats, mice, termites etc. and against unauthorized access.
- Store crates and boxes on pallets, timber beams or planks as protection against ground moisture and for improved ventilation.
- Ensure that the foundation has sufficient load-bearing capacity.
- Keep entrance paths clear.
- Check the stored goods at regular intervals. Also take appropriate action after storms, heavy rain or snow etc.

5.6 Further transport

Use the original product packaging for further transport.

If you transport the product to the final installation site in a mounted state, observe the following information in order to protect the product against mechanical damage due to external influences.

Transport packaging requirements

- Select packaging suitable for the duration of transport or storage, taking the climatic conditions into consideration.
- Ensure that the packaging protects the product against transport stress such as shaking, vibrations and impacts.
- Ensure that the packaging protects the product against moisture such as rain, snow and condensation.
- Ensure that the packaging allows for sufficient air circulation in order to prevent the formation of condensation.

This chapter describes how to install and connect the device correctly.

⚠ DANGER



Electric shock!

Risk of fatal injury due to electrical voltage. Always observe the following safety regulations when working in or on electrical equipment.

- ▶ Disconnect the system.
- ▶ Lock the system to prevent an unintentional restart.
- ▶ Ensure all poles are de-energized.
- ▶ Ground and short-circuit.
- ▶ Cover or cordon off adjacent energized parts.

NOTICE

Damage to the device!

Electrostatic discharge can lead to damage to the device.

- ▶ Take precautionary measures to prevent the build-up of electrostatic charges on work surfaces and personnel.

6 Installation

6.1 Installation recommendation



Figure 3: Installation recommendation

Recommended installation position

- 1 Side wall of the transformer, half way up

Alternative installation positions

- 2 Connection pipe from the cooling system to the transformer tank

Less recommended installation positions

- 3 On the side in the lower area; so long as oil circulation is ensured at the intended position, installing the device here may be considered
- 4 Connection pipe from the transformer tank to the cooling system: the oil temperatures here can be very high and influence the quality of the measurements

Impermissible installation positions

- 5 On top of the transformer cover, installed vertically (display faces upwards)



Ensure that the ventilation openings (see chapter Design [► Section 4.3, Page 18] and Drawings [► Section 14, Page 89]) are not covered and have at least 2 cm clearance to neighboring devices.

6.2 Mounting the device

NOTICE

Danger of damaging the device measuring pipe!

Closing a slide valve when the device is inserted can damage the measuring pipe.

- ▶ Do not close a slide valve when the device is inserted.
- ▶ Observe Mounting and Disassembly Instructions!
- ▶ Attach the warning sign "Do not close!" included in the delivery to the slide valve.
- ▶ Remove the warning sign after removing the device.

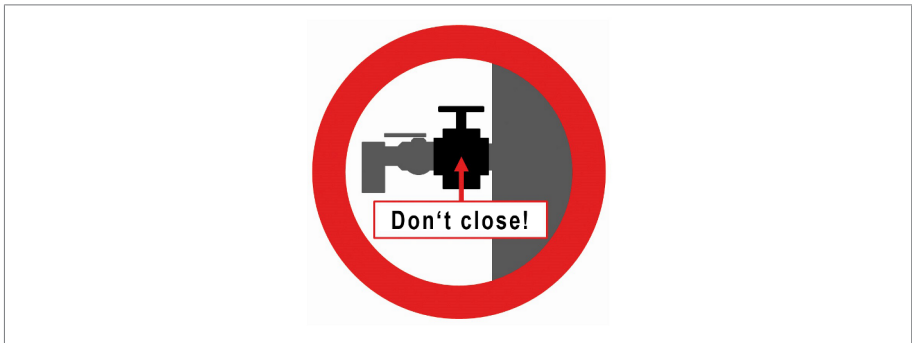

Figure 4: Warning sign on the ball valve

6.2.1 Preparing the transformer and ball valve

- ✓ A flange is mounted on the transformer that matches the device ball valve flange.
1. Carefully remove the ball valve from the packaging and protect against damage.

6 Installation

2. Remove the fixing screw from the dummy plug.

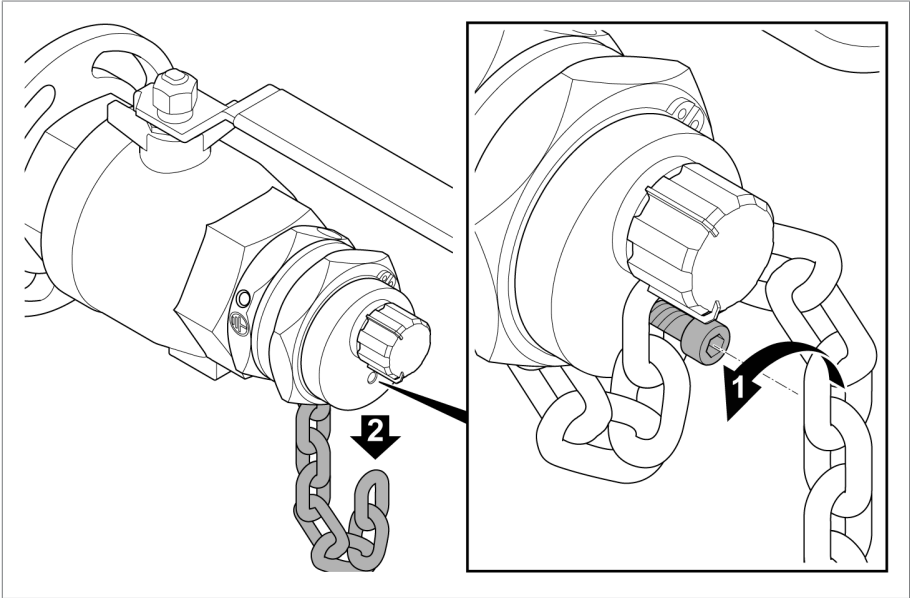

Figure 5: Unchaining the dummy plug

3. Release the clamp connection.

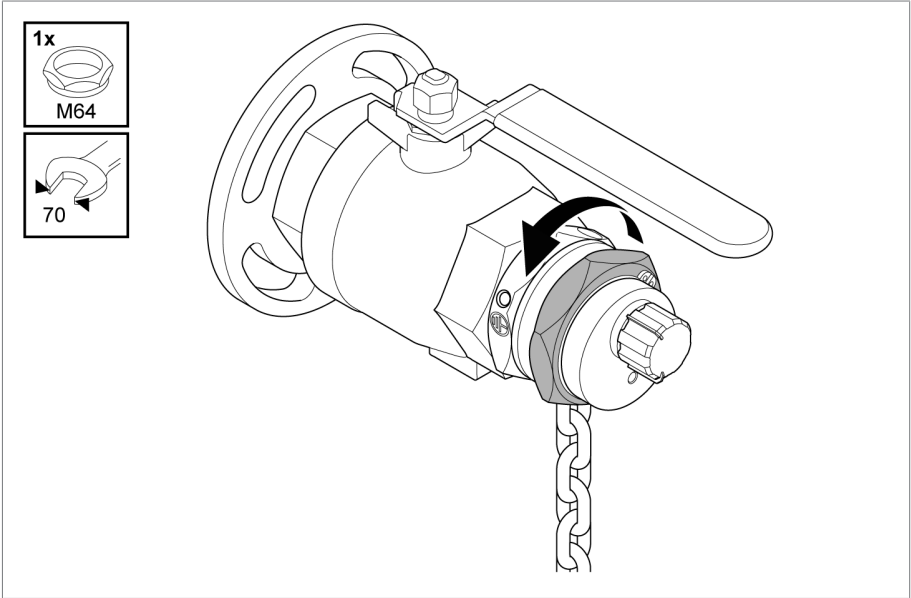

Figure 6: Releasing the clamp connection

6 Installation

4. Pulling the dummy plug out

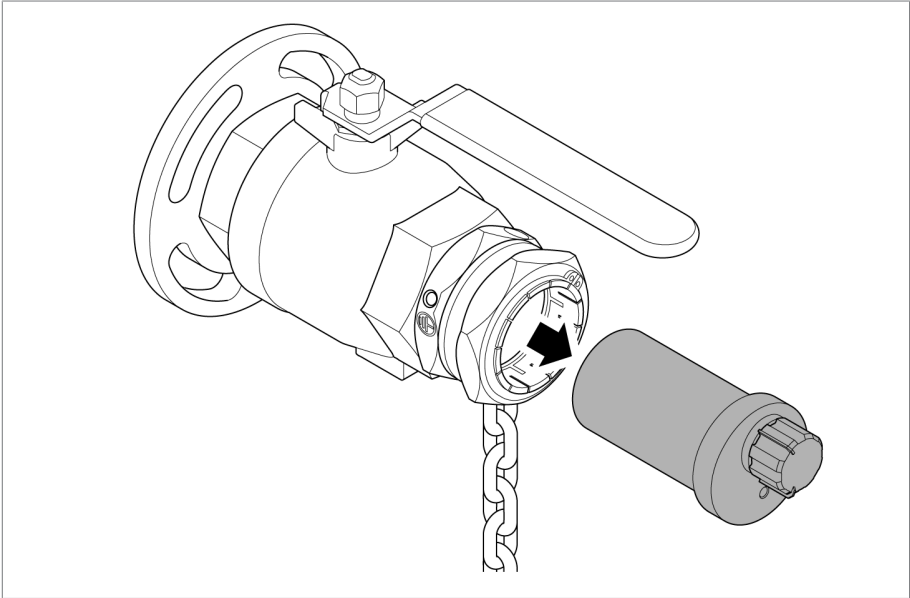

Figure 7: Pulling the dummy plug out



Package the dummy plug and store safely in case the device is to be removed at a later date.

5. Turn the ball valve lever to the "closed" position.

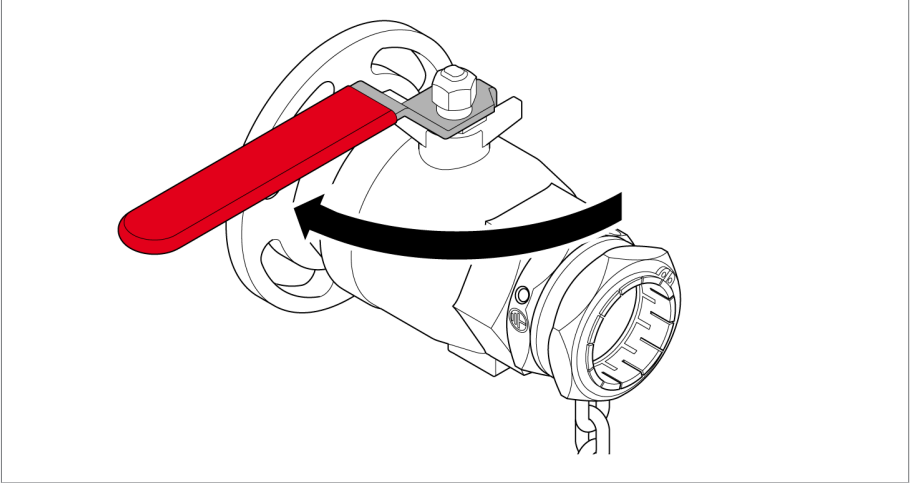

Figure 8: Closing the ball valve

NOTICE

Missing or incorrectly positioned round gasket

Non-tight seal and possible oil leakage.

- ▶ Ensure that all round gaskets remain in position in the ball valve when lubricating.

6 Installation

6. Lubricate the two round gaskets at the front of the ball valve.

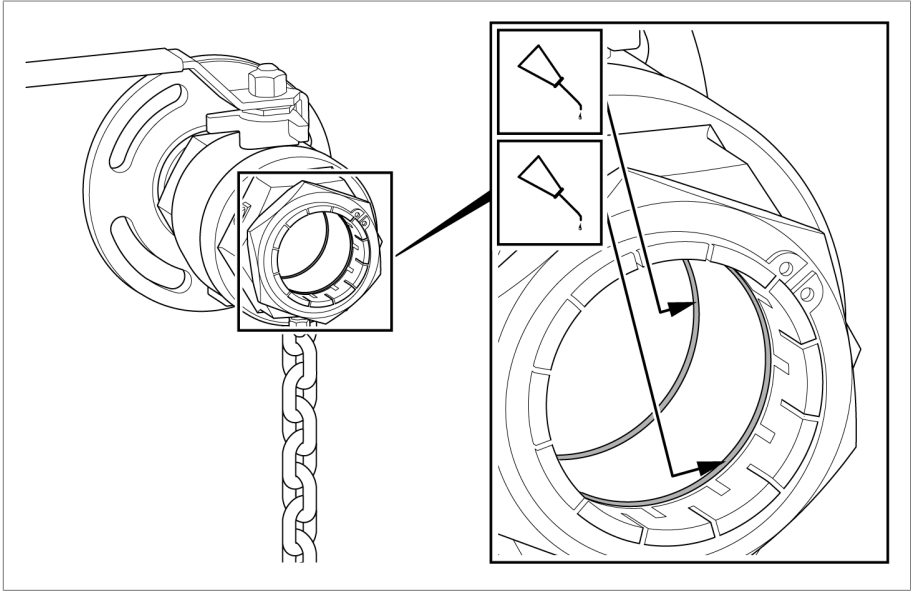

Figure 9: Lubricating the ball valve round gaskets

7. Lubricate the two round gaskets at the rear of the ball valve.

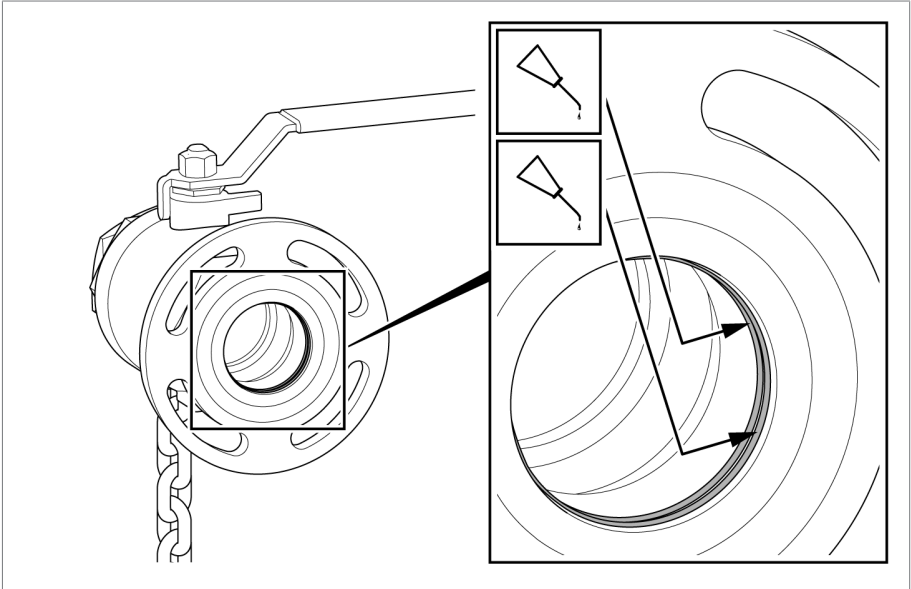

Figure 10: Lubricating the ball valve round gaskets

8. **NOTICE!** Mounting errors can lead to non-tight seals and thus uncontrolled oil leakage. Ensure that the flat gasket supplied is correctly positioned.
9. Mount the closed ball valve on the transformer and align via the elongated holes such that the locking lever is at the **top**. Use fastening materials made of stainless steel A4 in the strength category -70.

6 Installation

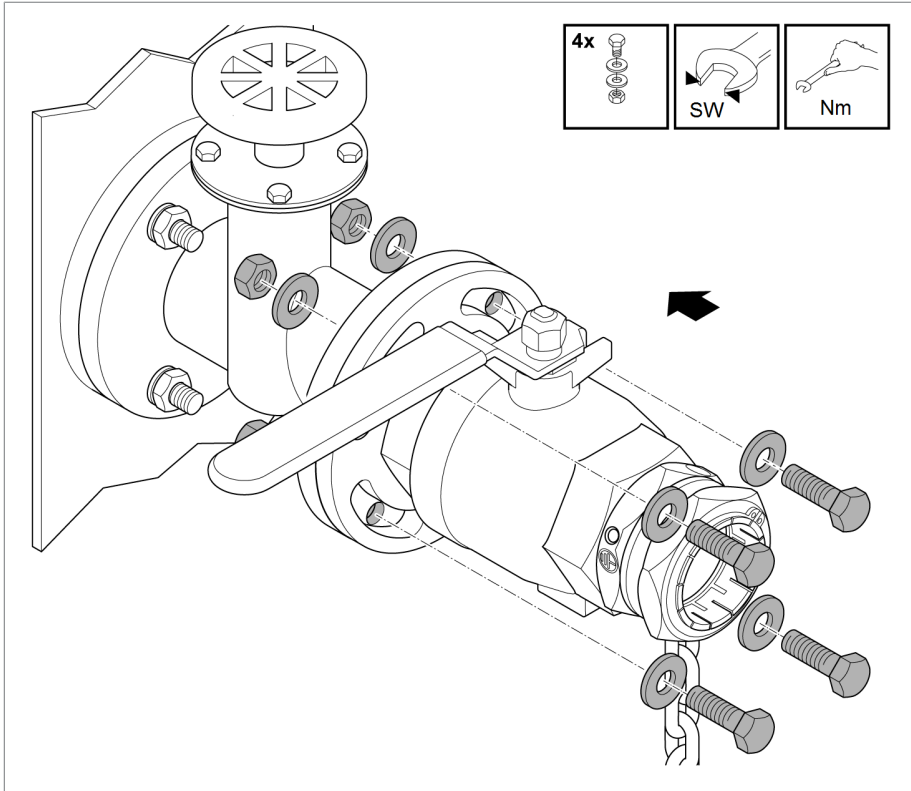

Figure 11: Mounting the closed ball valve

Flange	Screws	WAF	Nm
DN50 PN16	M16 A4-70	24	150
DN80 PN16	M16 A4-70	24	150

6.2.2 Mounting the device for online oil analysis

1. Remove the device from the packaging and place it securely on a scratch-resistant and non-slip level surface.

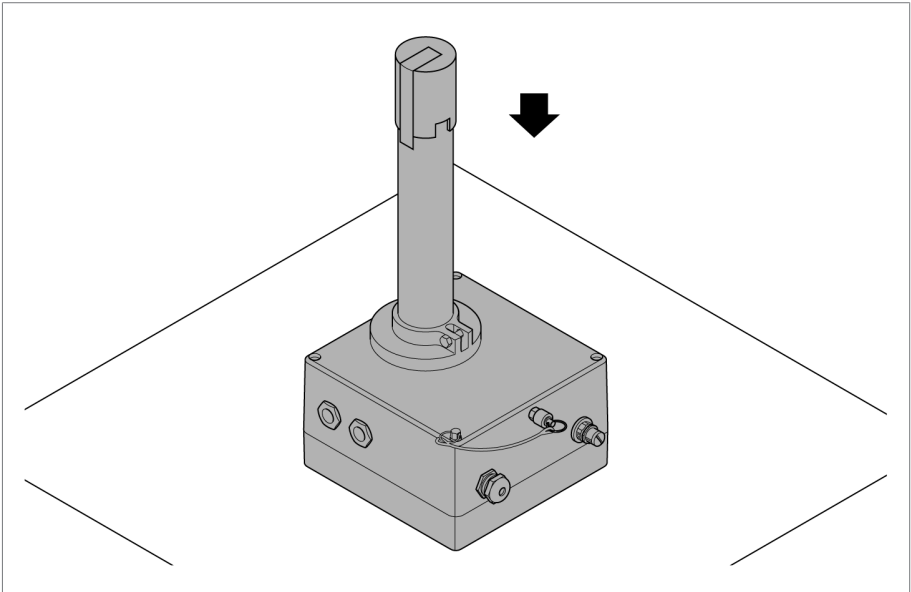

Figure 12: Setting the device down securely



When doing so, ensure that the display is not damaged.

6 Installation

2. Remove the adhesive strip from the protective cap and pull the protective cap off of the device.

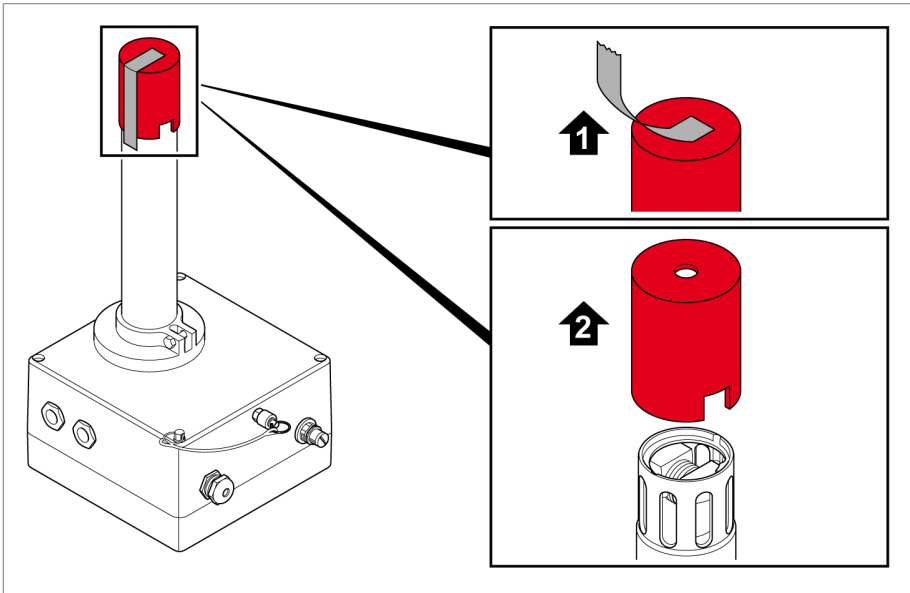

Figure 13: Removing the protective cap



Store the protective cap in case the device is to be removed at a later date.

3. Open the connection for taking oil samples. To do so, push the bayonet connector toward the device, hold down and pull the sealing plug out. Release the bayonet connector.

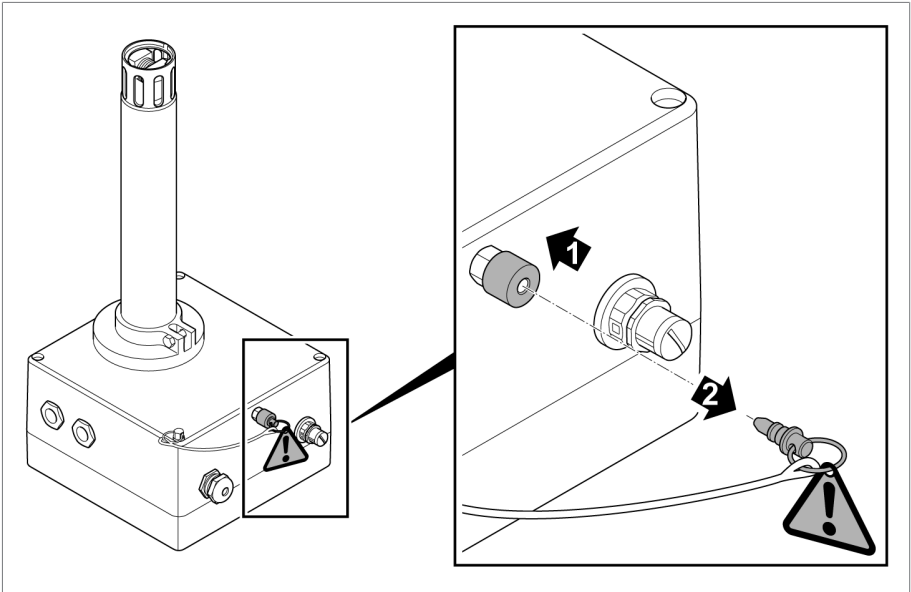

Figure 14: Opening the connection for venting and taking oil samples

6 Installation

4. **NOTICE!** Make sure the oil extraction adapter belongs to this device. If not, the oil extraction connection and adapter can become damaged. Push the supplied oil extraction adapter into the opening until it audibly snaps into place.

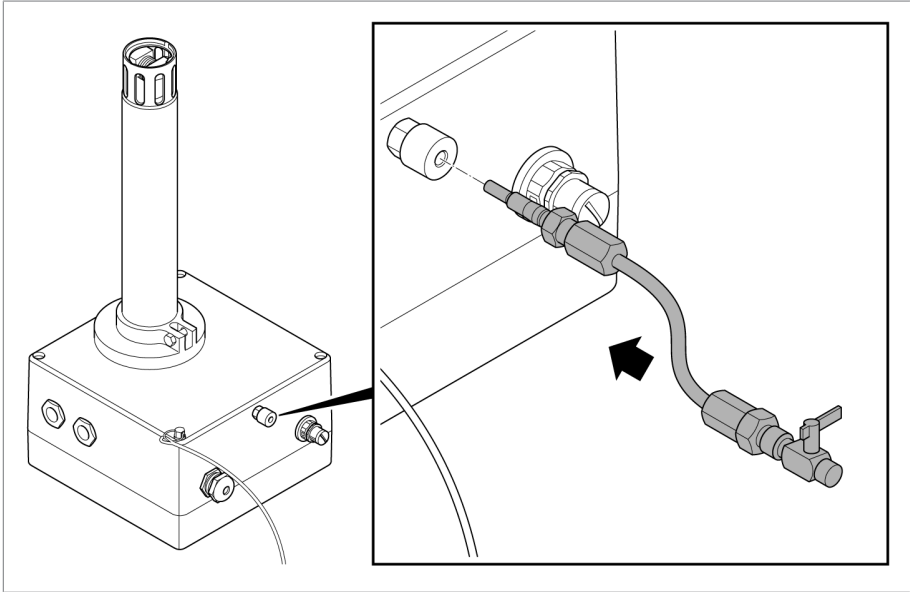

Figure 15: Connecting the oil extraction adapter

5. Open the oil extractor valve so that the air present can dissipate during further assembly.

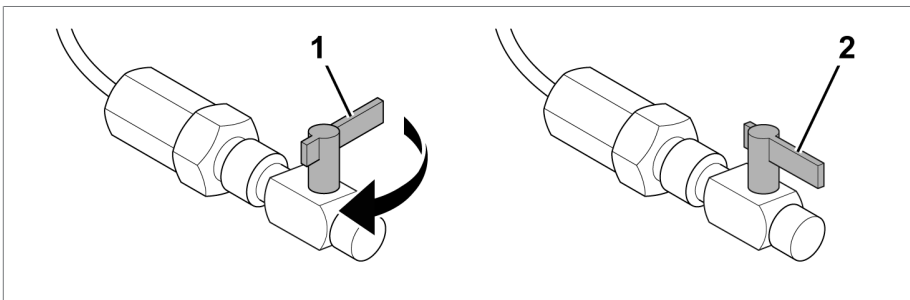

Figure 16: Opening the oil extraction adapter

6. Insert the measuring pipe into the closed ball valve.

NOTICE

Risk of damage

The device measuring pipe can become tilted when it is inserted into the ball valve.

- ▶ Support the weight of the device by hand and push the pipe into the ball valve with even pressure up to the stop (tangible resistance).

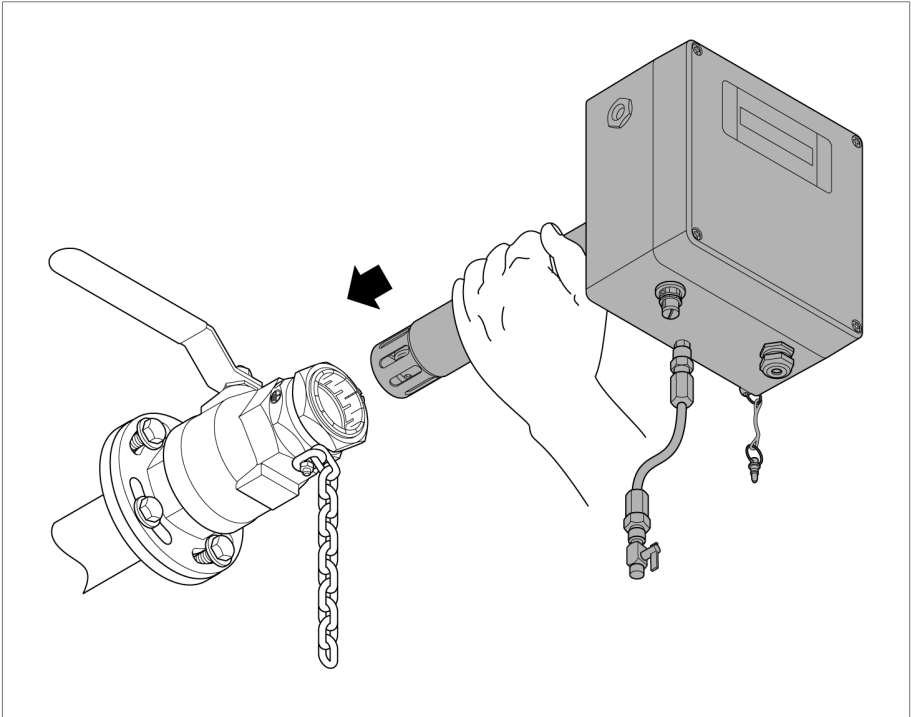

Figure 17: Inserting the device into the ball valve

6 Installation

- Unscrew the fixing screw for the safety chain on the device until the opening for the chain is free. Insert the last link of the safety chain into the opening, hold it in this position, thread the fixing screw through the chain link and tighten with a torque of 7 Nm.

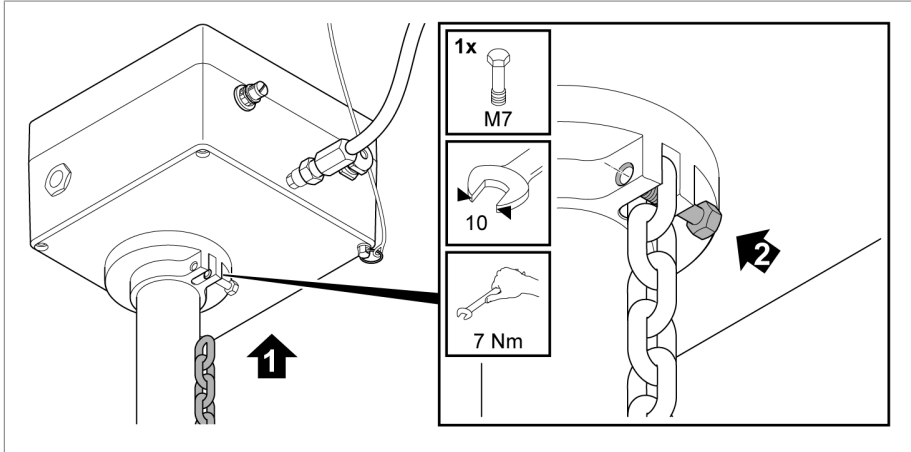

Figure 18: Inserting and securing the safety chain

⚠ CAUTION



Risk of burns

Hot oil can push the device out of the ball valve and spray out.

- Ensure that the safety chain is correctly bolted in place and does not sag.

6 Installation

8. Position a collecting tray below the valve opening in the oil extraction adapter and open the ball valve by aligning the lever up to the stop parallel to the measuring pipe.

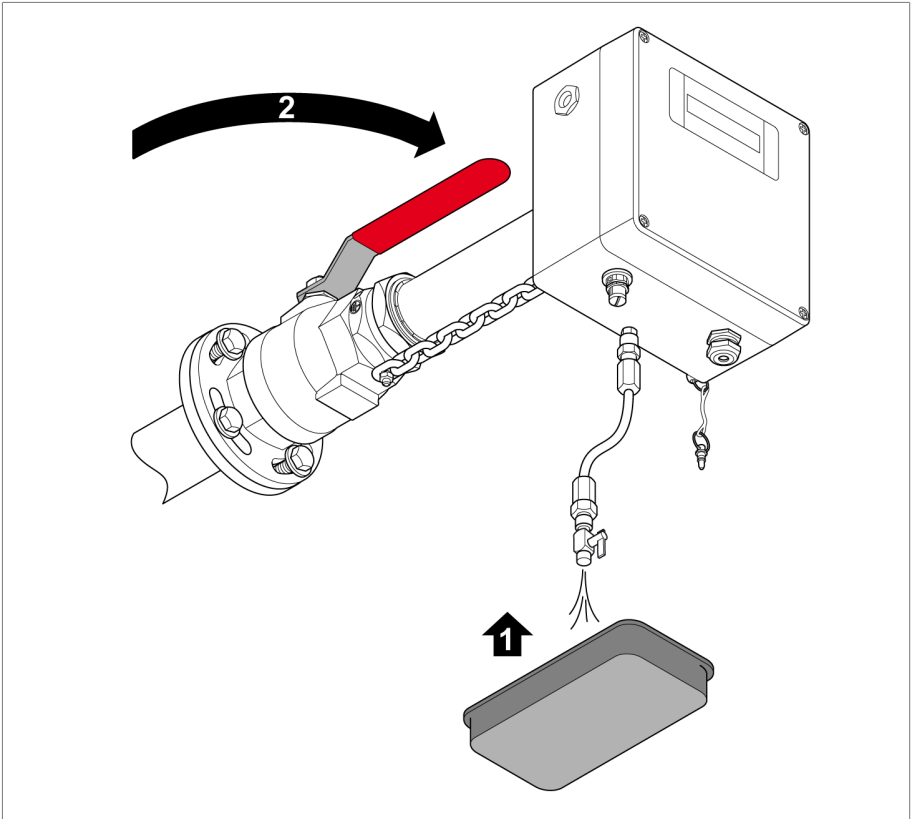

Figure 19: Venting the device

9. Open any upstream valves and slides.



Excess air will be purged from the system via the oil extraction adapter due to the pressure of the oil.

10. Vent the system until only oil flows out of the adapter.

6 Installation

11. Close the oil extraction adapter valve.

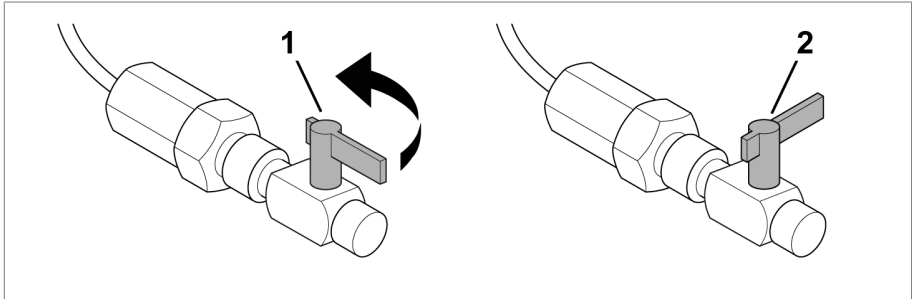

Figure 20: Closing the oil extraction adapter

12. Remove the adapter from the device. To do so, push the bayonet connector toward the device, hold down and pull the adapter out. Release the bayonet connector.

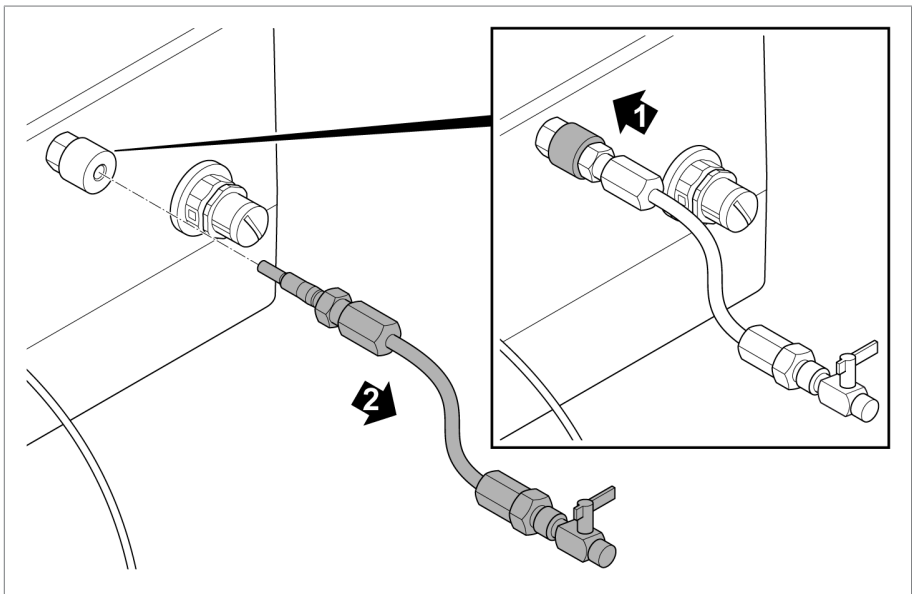

Figure 21: Removing the oil extraction adapter

- Put the sealing plug back on the bayonet connector for venting and taking oil samples and push it in until it snaps into place.

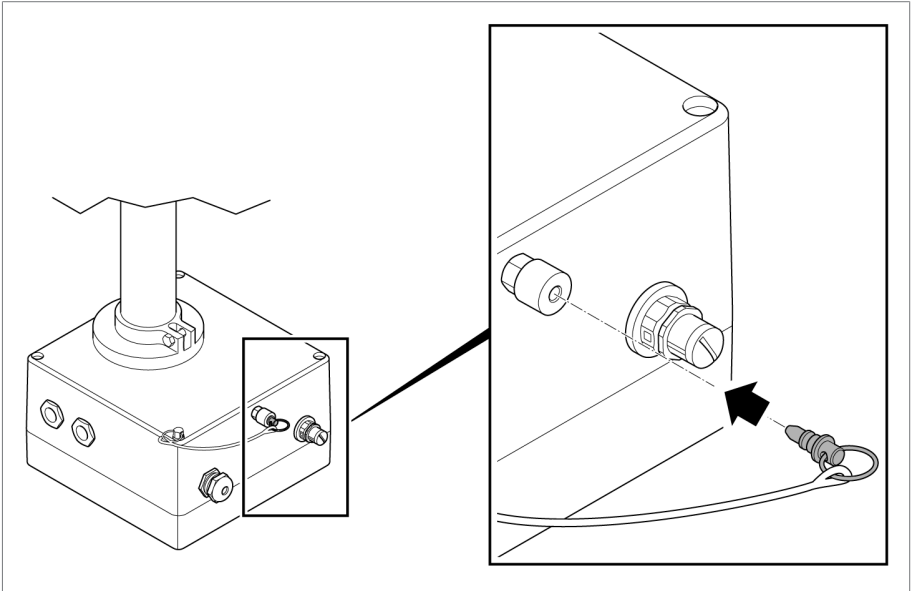

Figure 22: Inserting the sealing plug



Ensure that the connection is tightly sealed.

- Push the device as far as possible into the system.

6 Installation

▲ WARNING



Electric shock

Risk of fatal injury due to electrical voltage.

- ▶ Maintain the necessary distance from the active part of the transformer (see Dimensional drawings [▶ Section 14, Page 89]).

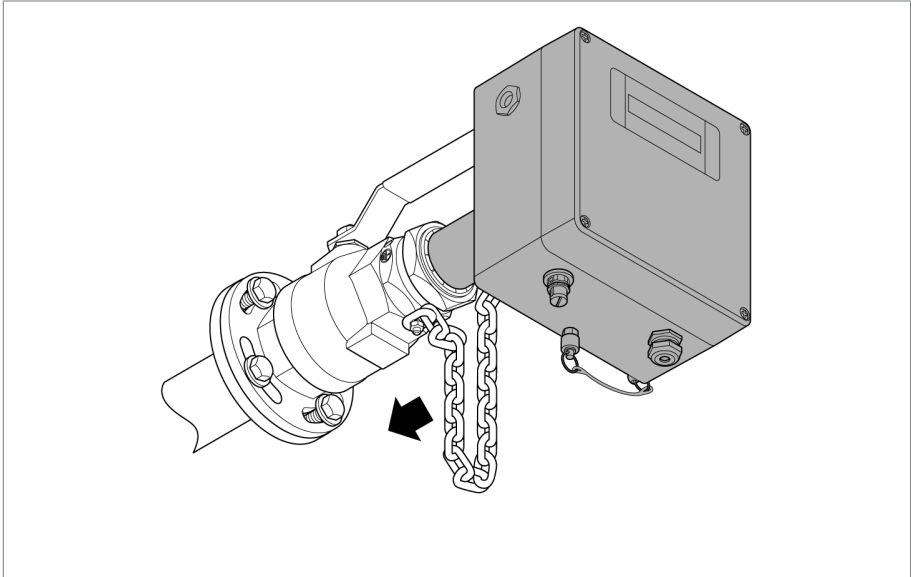

Figure 23: Pushing the device into the system

6 Installation

15. Tighten the ball valve clamp connection using a wrench (wrench size 70) with a torque of 140 Nm.

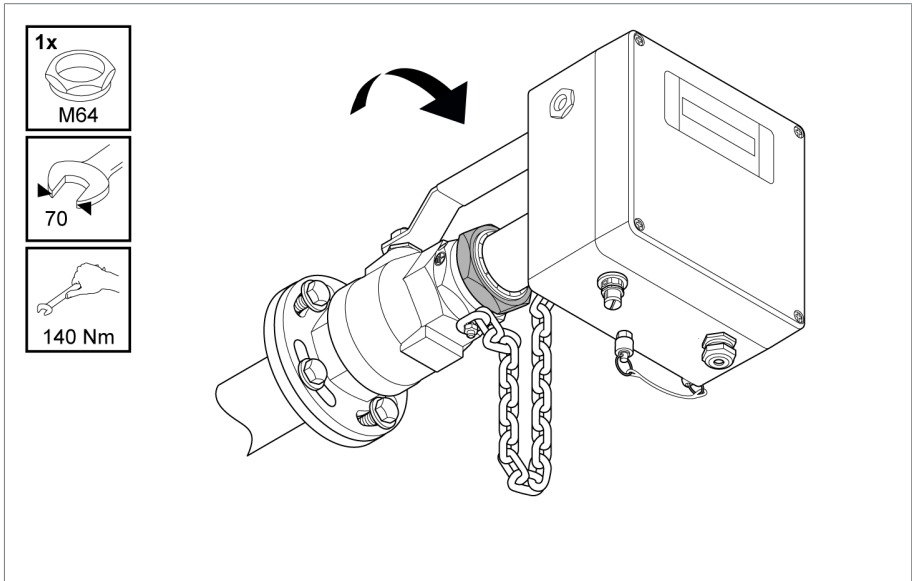

Figure 24: Tightening the ECOSENSE® ACTIVE PART

6 Installation

16. Reduce the length of the sagging safety chain by inserting the supplied chain connector through two links in the chain and closing it.

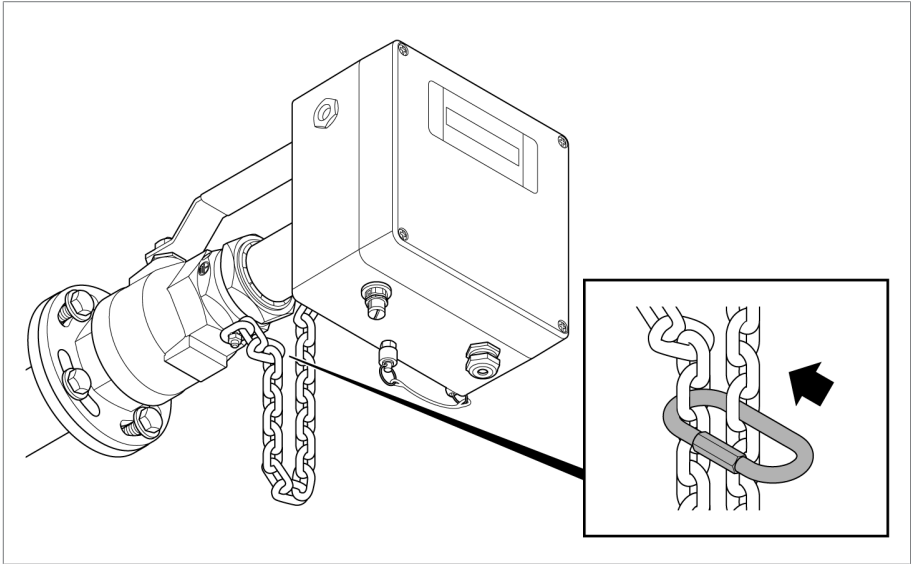

Figure 25: Locking the safety chain



Alternatively, a padlock can be used to secure the device against unauthorized removal.

Affixing the warning sign

- ▶ Warning sign "**Do not close!**" Attach the warning sign "Do not close!" to the shutter valve using the cable tie included.

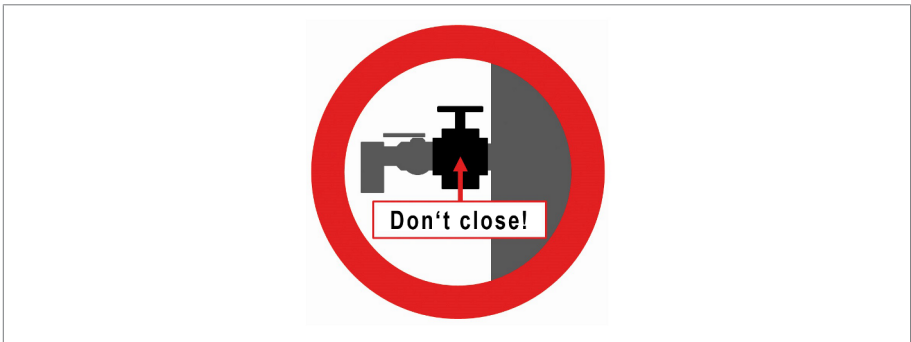

Figure 26: Warning sign

6.3 Electrical connection

This chapter describes the correct electrical connection of the device.

▲ WARNING



Electric shock

Risk of fatal injury due to electrical voltage.

- ▶ De-energize the device and system peripherals and take measures to ensure that they cannot be switched back on.

Only connect the device to circuits with an external overcurrent protection device and an all-pole isolating device so that the equipment can be fully de-energized if required (for service, maintenance, etc.).

Suitable equipment includes isolating devices in accordance with IEC 60947-1 and IEC 60947-3 (e.g. circuit breakers). Note the properties of the relevant circuits (voltage, maximum currents) when selecting the circuit breaker type. In addition, observe the following:

- It must be easy for the operator to access the isolating device
- The isolating device must be labeled for the device and circuits to be isolated
- The isolating device may not be a part of the power line
- The isolating device may not interrupt the main protective conductor

Miniature circuit breaker

We recommend the use of a miniature circuit breaker for protecting the supply circuit:

- Rated current: 16 A
- Triggering characteristic: C

Conductor cross-section

For the supply circuit, use a conductor cross-section suitable for the overcurrent protective device that you have selected and the selected cable length, but at least 1.5 mm² (AWG 15).

6 Installation

Wiring information

Note this procedure for the wiring:

- ✓ To obtain a better overview when connecting cables, only use as many leads as necessary.
 - ✓ Note the connection diagram.
 - ✓ Only use specified cables for wiring. Note the cable recommendation.
 - ✓ Wire the system periphery leads.
1. Strip insulation from leads and wires.
 2. Crimp stranded wires with wire end sleeves.

6.3.1 Electromagnetic compatibility

The device has been developed in accordance with applicable EMC standards. The following points must be observed in order to maintain the EMC standards.

- The system's overvoltage protection must be effective.
- The system's ground connection must comply with all technical regulations.
- For signal transmission, use shielded leads with individual conductors (outgoing conductor / return conductor) twisted in pairs.
- Connect full surface of shielding to device or to a nearby grounding bar.

6.3.2 Cable recommendation



The connection cables used must comply with a temperature resistance within the permissible ambient temperature of -40...+60 °C.

Cable	Terminal*	Cable type
Power supply	1, 2, 3	Unshielded

Table 5: Recommendation for connection cables

*) Also refer to Terminal technical data.

6.3.3 Routing and preparing the cables

Consider the position of the connections when preparing the cables (see chapter Electrical connection).



Ensure that the length of the PE conductor (terminal 3) is at least 50 mm longer than the supply voltage conductors (terminals 1 and 2).

To prepare the cable correctly, proceed as follows:

1. Open the device connection area. To do so, unscrew the 4 captive screws on the housing cover. The cover is connected to the device via hinges and can be flipped open.
2. Remove the supply voltage cable jacket and cut the cable such that the length of the PE wire is 50 mm longer than the wires for L and N. Strip 7 mm (1/4") of the insulation from the wires and cap them off with ferrules.

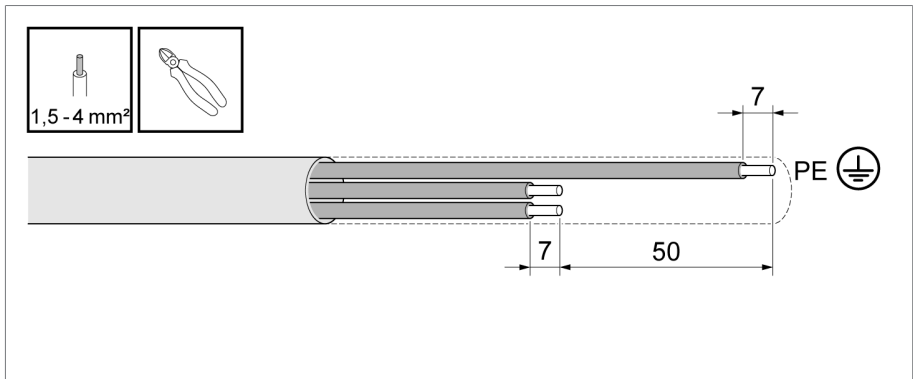

Figure 27: Preparing the cable

3. Unscrew the cable gland (M20x1.5).
4. Insert a sufficient length of cable through the cable gland and rubber gasket and tighten the cable gland so that moisture cannot penetrate into the connection area from outside.

6.3.4 Supply voltage and protective conductor

In order to connect the cable for the supply voltage and the protective conductor, proceed as follows:

1. Insert wire for the protective conductor into terminal 3 (PE) and tighten the screw terminal to 0.5 Nm.

6 Installation

2. Insert wires for the supply voltage into terminal 1 and terminal 2 and tighten the screw terminals to 0.5 Nm.

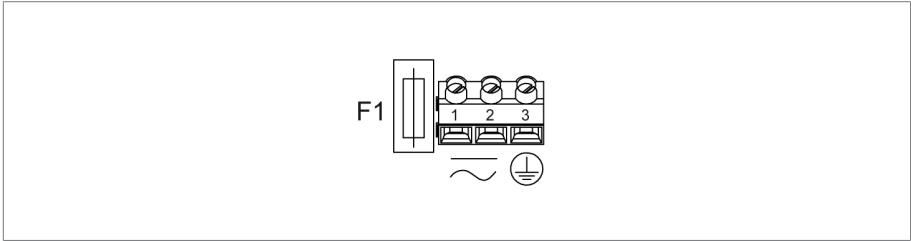

Figure 28: Supply voltage and protective ground connection



Ensure that the protective conductor cross-section is at least the same as all other connection conductors.

6.3.5 Device grounding

Connect the ground connection on the device ball valve to the transformer ground connection.

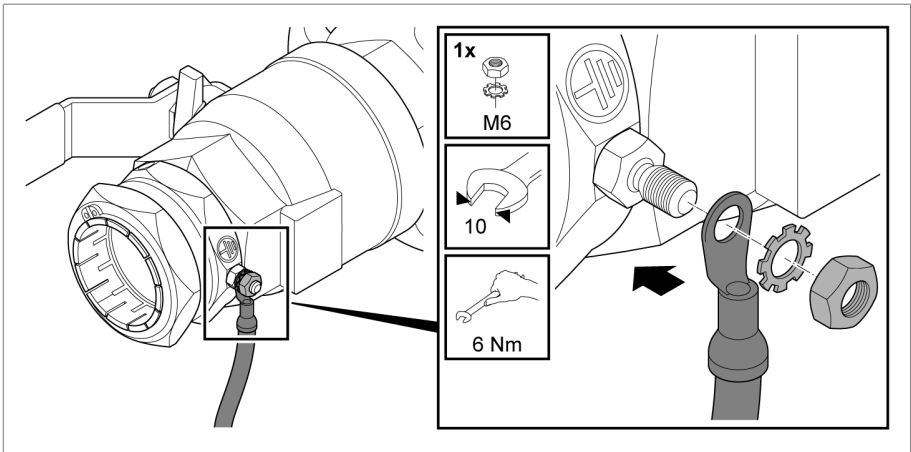

Figure 29: Ground connection

6.3.6 SCADA connection

6.3.6.1 Standard interface Modbus RTU

The device can be connected with a SCADA system via the Modbus interface. This is designed as a 4-conductor system [► Section 6.3.6.4, Page 50], but can also be integrated into a 2-conductor system [► Section 6.3.6.5, Page 51].

The following signals are available in the 4-conductor system via the M12 socket:

M12 socket / Modbus (RTU) interface assignment

PIN	4-conductor system	2-conductor system
1	TXD0 / TX+ / Y	D0 / D+ / A
2	TXD1 / TX- / Z	D1 / D- / B
3	RXD1 / RX- / B	D1 / D- / B
4	RXD0 / RX+ / A	D0 / D+ / A
5	Common	Common

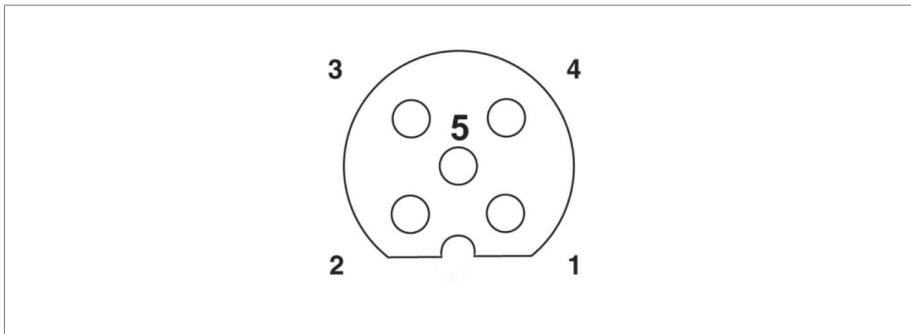

Figure 30: Integrated device socket (schematic)

6.3.6.2 Setting the Modbus RTU transmission speed

You can configure the following settings for the Modbus RTU interface using the MESSKO® MSET parameterization software:

Device address: 1 to 247

Baud rate: 4800, 9600, ...115200

6 Installation

Parity: even

Detailed information is available in the MESSKO® MSET parameterization software operating instructions.

6.3.6.3 Modbus RTU protocol

The data point table for the Modbus RTU protocol is available in the Appendix [► Section 15.1, Page 93].

Comprehensive information on Modbus is available on the Internet: <http://www.modbus.org/>.

6.3.6.4 Integration of the device into a 4-conductor system

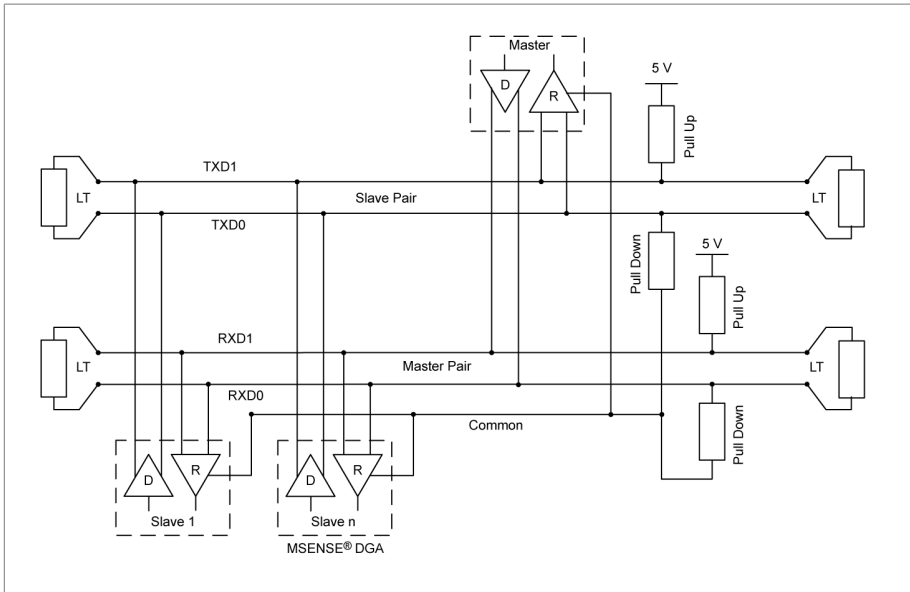

Figure 31: 4-conductor system

6.3.6.5 Integration of the device into a 2-conductor system

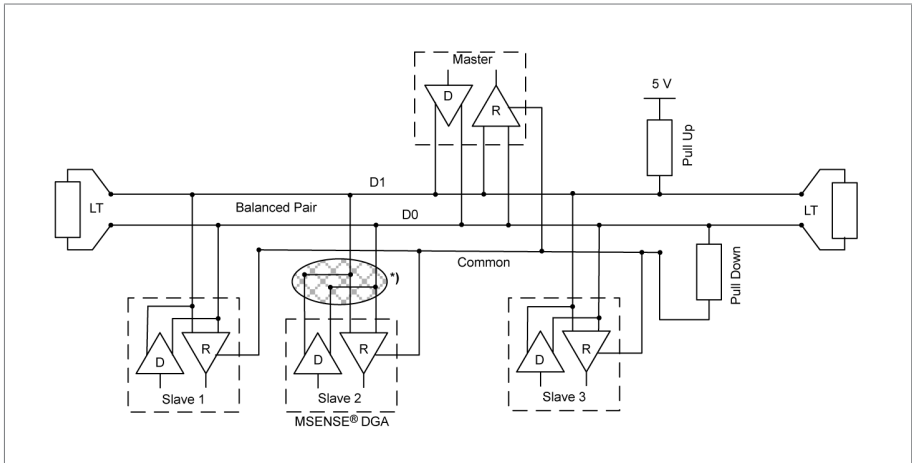

Figure 32: 2-conductor system

*) When integrating the device into a 2-conductor system, the following conductors are to be bridged in the external supply line:

- Conductors TXD0 (pin 1) and RXD0 (pin 4)
- Conductors TXD1 (pin 2) and RXD1 (pin 3)

7 Commissioning

NOTICE

Damage to the device!

Damage to the electronics of the device due to incorrect supply voltage!

- ▶ Provide the correct supply voltage in accordance with the nameplate on an external isolating device.

The device is ready for operation once it has been connected to the supply voltage and completed a run-in period of at least 24 hours. Measured values displayed during the run-in period do not reflect the true gas or moisture concentrations. For this reason, alarms and warnings can be ignored during the run-in period. The run-in period is to ensure the thermal stabilization of the measuring system and is indicated on the display by an "!" in the display of the gases H₂ and CO.

The device takes measurements four times within 24 hours by default. This measurement interval can be changed using the MESSKO® MSET parameterization software (see corresponding operating instructions).



The device is calibrated at the factory for fresh mineral-based insulating oils (Standard **ASTM D3486-091** or **IEC 60422**).

7.1 Service interface

The system is equipped with a service interface for configuring extended settings via the MESSKO® MSET parameterization software supplied.

NOTICE

Damage to the device and PC/laptop

Potential differences can cause the devices to be destroyed.

- ▶ Ensure that the device supply voltage and the PC/laptop supply voltage have the same ground potential (PE).
- ▶ Use the outlet in the control cabinet.
- ▶ Operate a laptop in battery mode wherever possible.

Proceed as follows:

1. Plug the screw connection of the USB service adapter onto plug connector 11 in accordance with the figure in the chapter "Design" and tighten the screw connection by hand.

2. Connect the device service adapter USB plug to the PC or laptop on which the MESSKO® MSET parameterization software is installed (see corresponding operating instructions).

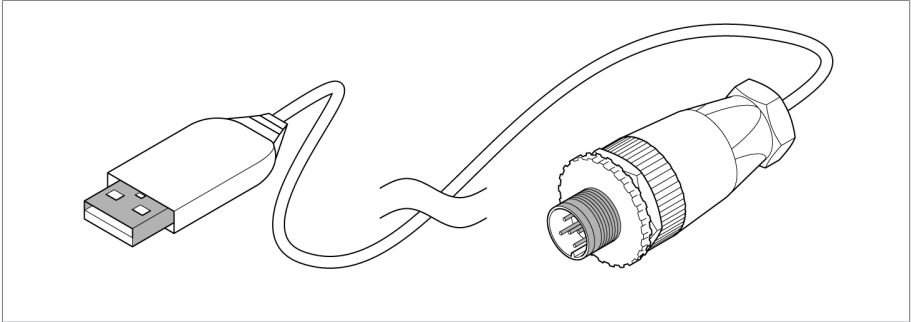

Figure 33: USB service adapter

⇒ The device can now be parameterized via the MESSKO® MSET parameterization software.

7.2 Installing the MESSKO® MSET parameterization software

You can download the latest version of the MESSKO® MSET parameterization software from the MR Reinhausen customer portal.

1. Register for download in the customer portal:
<https://portal.reinhausen.com>.
2. Create your ECOSENSE® ACTIVE PART under **myEquipment > Components**.
3. Then enter the serial number under **mySelfServices > Software updates**.



The Microsoft Windows 10 operating system or later is necessary for installing the MESSKO® MSET parameterization software.

To install the MESSKO® MSET parameterization software, proceed as follows:

1. Start the MSETSetup.exe setup file.
2. Select the language in which you want to run the installation process.
3. Follow the instructions in the setup wizard.
4. Upon successful installation, the program can be started via Start > All programs > MESSKO > MSET > MSET program icon.

7 Commissioning



Detailed information on using the MESSKO® MSET parameterization software can be found in the corresponding operating instructions.

7.3 Commissioning in existing systems

The manufacturer recommends a field calibration of the device parameters to ensure optimum operation, in particular with:

- Aged insulating oils
- Modified oils (e.g., the addition of additives)
- Oils that do not satisfy the standards ASTM D3486-091, IEC 60296 or IEC 60422.

For this purpose, an oil sample must be taken in accordance with the chapter "Oil extraction" and sent to a qualified oil laboratory. You will then receive a recommendation for action for readjustment that you can perform via the MESSKO® MSET parameterization software.

7.4 Parameterization

Parameterization of the device is only possible in combination with the MESSKO® MSET parameterization software, and is described in detail in the corresponding operating instructions.

The following settings can be configured for the parameters CO, H₂ and H₂O (as relative or absolute):

- Concentration warning limit
- Concentration alarm limit
- Gas formation rate warning limit
- Gas formation rate alarm limit

Further settings

- H₂O reference
- Measurement interval
- Time stamp
- UNIX time stamp
- Service code
- Modbus baud rate

- Modbus address
- Service database
- Field calibration
- Default calibration

7.4.1 Settings for carbon monoxide, hydrogen and moisture in oil concentrations

The upper warning and alarm values for the carbon monoxide content (CO), the hydrogen content (H₂) and the H₂O concentration can be specified.

Along with the limit values specified in the standards, you have the option here of determining system-specific limits based on data collected or empirical values.

You can configure the respective settings using the MESSKO® MSET parameterization software in accordance with the corresponding operating instructions.

Carbon monoxide (CO) limit values

Limit value	Default*)	Minimum	Maximum
Concentration too high warning	350 ppm	0 ppm	2,000 ppm
Concentration too high alarm	570 ppm	0 ppm	200 ppm
Gas formation rate too high warning	30 ppm/d	0 ppm/d	80 ppm/d
Gas formation rate too high alarm	50 ppm/d	0 ppm/d	80 ppm/d

Table 6: Carbon monoxide (CO) limit values

*) Recommended values based on IEEE C57.104, Condition 1

Hydrogen (H₂) limit values

Limit value	Default*)	Minimum	Maximum
Concentration too high warning	500 ppm	0 ppm	2,000 ppm
Concentration too high alarm	700 ppm	0 ppm	2,000 ppm
Gas formation rate too high warning	30 ppm/d	0 ppm/d	80 ppm/d
Gas formation rate too high alarm	50 ppm/d	0 ppm/d	80 ppm/d

Table 7: Hydrogen (H₂) limit values

*) Recommended values based on IEEE C57.104, Condition 1

7 Commissioning

Moisture (H₂O) limit values

Limit value	Default	Minimum	Maximum
Concentration too high warning	30% RH	0% RH	100% RH
Concentration too high alarm	45% RH	0% RH	100% RH
Gas formation rate too high warning	10% RH/d	0% RH/d	100% RH/d
Gas formation rate too high alarm	15% RH/d	0% RH/d	100% RH/d

Table 8: Moisture (H₂O) limit values

7.4.2 General settings

Proceed in accordance with the description in the MESSKO® MSET parameterization software operating instructions in order to adjust the following listed settings where necessary.

Measurement interval setting

The measurement interval is the time between two measurements (in hours). The shortest measurement interval is 3 hours.

Measurement interval	
Standard value	6 hours
Maximum value	24 hours
Minimum value	3 hours

H₂O reference setting

The analysis results of the oil laboratory can be entered here in order to make a comparison between the water content (H₂O in ppm) of the ECOSENSE® ACTIVE PART analysis and that of the laboratory. A field comparison for the gases H₂ and CO is performed in the service area of the MSET software (see chapter Maintenance [► Section 10, Page 65]).

Time stamp

Make a note of the time stamp of the oil sample extraction for the laboratory. This is needed for the water content (H₂O in ppm) calibration. The time stamp is updated with service code 1: sample extraction.

7 Commissioning

Once the sample has been analyzed by a laboratory, the time stamp must be entered together with the analysis results for adjustment via the MESSKO® MSET parameterization software. To do so, use the service code 33.

Service code

Proceed in accordance with the description in the MESSKO® MSET parameterization software operating instructions in order to enter and transmit a service code.

Service code	Description
0	No action.
1	Sample extraction: This service code informs the device that an oil sample has been taken for calibrating the absolute humidity H ₂ O. Please be sure to note the time stamp on the sample information sheet! Important: Adjustment is not possible unless a time stamp is set! Note: The following conditions must exist for the device to permit an adjustment: Oil temperature at sample extraction: +10 to +90 °C Ambient temperature at sample extraction: -20 to +60 °C For adjustment of the gases H ₂ and CO: Lab result (reference value) >50 ppm For adjustment of the absolute humidity H ₂ O (ppm): Lab result (reference value) >5 ppm
4	Absolute humidity [ppm]: The humidity (H ₂ O) determined in the oil is output as the absolute humidity with the unit [ppm]. Warnings and alarms are evaluated only for the absolute humidity.
5	Relative humidity [%RH] (default): The humidity (H ₂ O) determined in the oil is displayed as the relative humidity with the unit [%RH]. Warnings and alarms are evaluated only for the relative humidity.
33	New calibration of the H₂O value: First enter the analysis results for the H ₂ O reference and the time stamp of the sample extraction in the "Settings" menu. Then enter service code 33 here. Determine the new reference value at the device through the final synchronization.

7.4.3 Modbus settings

You can configure the following settings for the Modbus communication using the MESSKO® MSET parameterization software.

7 Commissioning

Modbus baud rate setting

The transmission speed (baud rate) of the Modbus interface can be set as follows: 4800, 9600, 19200, 38400, 57600, 115200 Bd.

Modbus baud rate	
Standard value	19200 Bd
Maximum value	115200 BD
Minimum value	4800 BD



Take into consideration a minimum pause of 500 ms between two Modbus requests.

Modbus address setting

The following values are available for the Modbus address:

Modbus address	
Standard value	1
Maximum value	247
Minimum value	1



Issuing the same network address twice will lead to malfunctions.

Parity

For data transmission, the parity is determined as follows:

Parity	
Fixed specification	Even

Ensure that the same Modbus settings are made in your SCADA system.

8.1 Main screen / Operating display

The following displays appear in rotation once the device has been commissioned:

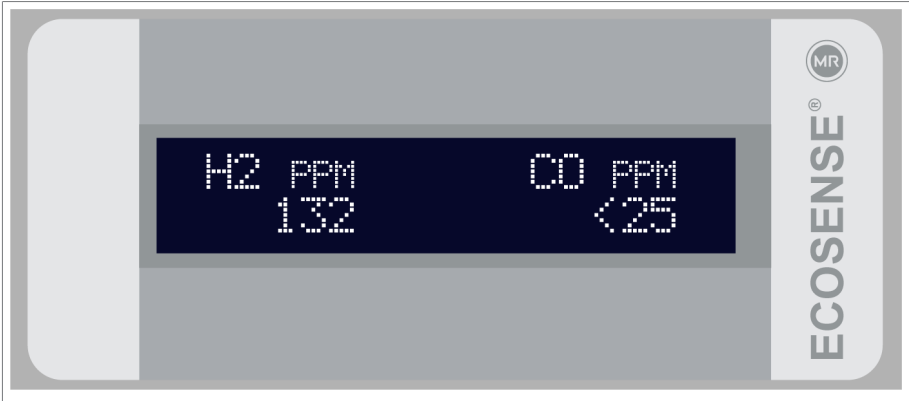

Figure 34: Display with current H₂ and CO content

Left-hand side	Right-hand side
H ₂ Hydrogen content in ppm	CO Carbon monoxide content in ppm

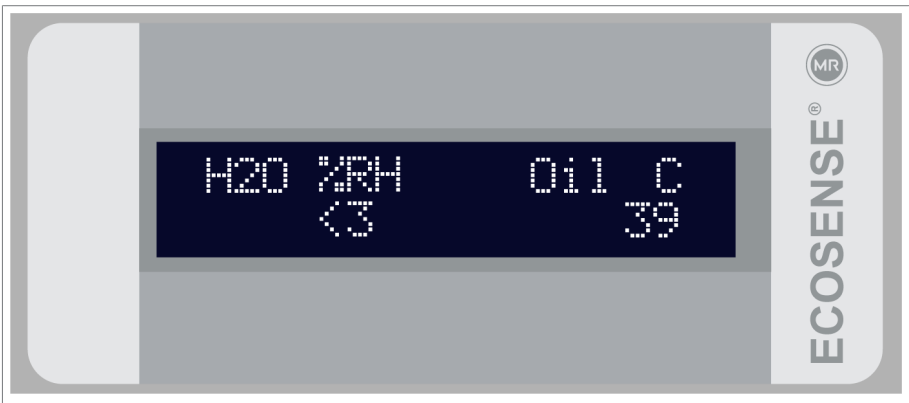

Figure 35: Display with current H₂O content and oil temperature

Left-hand side	Right-hand side
H ₂ O Water content (humidity) in %RH ¹⁾	Oil Oil temperature in °C

8 Operation

¹⁾ The water content (humidity) display can be converted from %RH to ppm via the MESSKO® MSET parameterization software if required (service code 4 and 5). When the measured data is transmitted (e.g. to a SCADA control center or a laptop), the water content is always transmitted in both display formats.

If an asterisk (*) is displayed, the system is outside the specified measuring range in accordance with the chapter "Technical data" [► Section 13, Page 86]. The following applies to the displayed measured value:

- During the first measurement after the running-in phase, the value of the lower detection limit is displayed.
- If measured values within the specified measuring range have already been recorded, then the last valid measured value is displayed.

The asterisk (*) disappears automatically as soon as the system is back in the valid measuring range.

The default settings for the warning and alarm limits are in accordance with the directives of IEEE C57.104 (for H₂ and CO) and DIN EN 60422 (for water content in oil).

You can adjust the limit values to your requirements via the MESSKO® MSET parameterization software.

The gas formation rates can be set as both positive and negative values.

The configurable parameters per sensor value are:

- Concentration too high warning
- Concentration too high alarm
- Formation rate too high warning
- Formation rate too high alarm



Any alarms, warnings or other messages present are only shown in the display for as long as the set threshold value is exceeded.

	H ₂	CO	H ₂ O	
	[ppm]	[ppm]	[%RH]	[ppm] ²⁾
Warning	500 ppm	350 ppm	30% RH	20 ppm
Alarm	700 ppm	570 ppm	45% RH	30 ppm
Gas formation rate warning	30 ppm/d	30 ppm/d	10% RH	10 ppm/d
Gas formation rate alarm	50 ppm/d	50 ppm/d	15% RH	15 ppm/d

²⁾ For mineral-based insulating oils

These limits and rates are suitable for initial commissioning. However, the systems (transformer and device) must be aligned with each other over time. Thus, with sufficient data, the limits / formation rates for the "warning" and "alarm" values should be able to be calculated and loaded via the MESSKO® MSET parameterization software.

8.2 Events

If a set warning or alarm limit is exceeded, this will be shown on the display in rotation with the measured values (CO[ppm], H₂[ppm], H₂O[ppm/%RH], Oil[°C]) as follows:



Figure 36: Warning

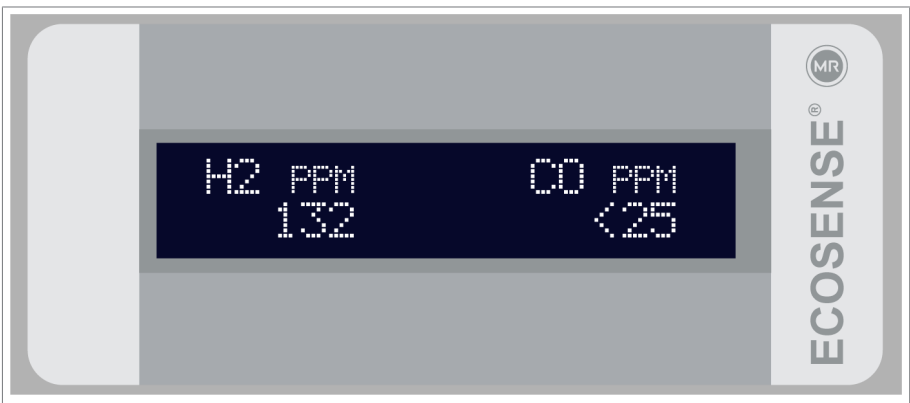

Figure 37: Measured values

8 Operation

The following table lists the possible events and the respective recommended actions:

Event	Text display	Recommended action
CO concentration warning	CO Warn.	1
CO concentration alarm	CO Alarm	2
CO gas formation rate warning	CO Formation Warn.	1
CO gas formation rate alarm	CO Formation Alarm	2
H ₂ concentration warning	H ₂ Warn.	1
H ₂ concentration alarm	H ₂ Alarm	2
H ₂ gas formation rate warning	H ₂ Formation Warn.	1
H ₂ gas formation rate alarm	H ₂ Formation Alarm	2
H ₂ O concentration warning	H ₂ O Warn.	1
H ₂ O concentration alarm	H ₂ O Alarm	2
H ₂ O gas formation rate warning	H ₂ O Formation Warn.	1
H ₂ O gas formation rate alarm	H ₂ O Formation Alarm	1

These events are saved in the database on the device and can be loaded onto the PC with the MESSKO® MSET parameterization software. The text display you can read directly on the display.

No.	Recommended action
1	<p>Please monitor your system and have an oil sample [► Section 10.3, Page 67] analyzed in a laboratory (at least DGA and humidity determination) in good time.</p> <p>Further procedures in accordance with the action instructions derived from the laboratory results.</p>
2	<p>Please monitor your system and have an oil sample [► Section 10.3, Page 67] analyzed in a laboratory (at least DGA and humidity determination) in good time.</p> <p>Reduce the system load until the action instructions derived from the laboratory results are available.</p>

This chapter describes how to eliminate operating faults.

9.1 Display faults

Characteristic/detail	Cause	Remedy
Display no longer shows events	Display fault	Check wiring. If OK: Interrupt supply voltage for 5 seconds. This activates a restart.
Display without function	Safety fuse defective	Follow the instructions in the "Replacing a fuse" [► Section 9.2, Page 63] section

9.2 Replace safety fuse

The device is fused with a safety fuse.

This can be replaced by a replacement fuse (500 mA, 500 V, 5x20 mm, delayed-action) if needed.

⚠ WARNING



Electric shock

Risk of fatal injury due to electrical voltage

- Only appropriately trained personnel may replace the fuse.
- Before opening the connection area in order to replace the fuse, the device is to be disconnected from all voltage sources via the prescribed disconnecting switch and secured against reconnection. The device must be grounded.

In order to replace the fuse, proceed as follows:

1. Disconnect device from all voltage sources.
2. Open the device connection area. To do so, unscrew the 4 captive screws on the housing cover. The cover is connected to the device via hinges and can be flipped open.
3. Remove the safety cover.
4. Using a screwdriver, carefully move under one end of the fuse and lift it out of the holder.

9 Fault elimination

5. Remove the fuse.
6. Position the replacement fuse with both ends on the holder and carefully press down until it locks into place.
7. Replace the safety cover.
8. Close the connection area.

Inspection and maintenance are required for the operational safety and to maintain measurement accuracy.

10.1 Inspection

Monitoring of the device is limited to occasional visual inspections and a regular oil extraction. For efficiency reasons, these inspection tasks can be combined with the usual checks on the transformer.

Check the following:

Interval	Recommended measure
Annually	Visual inspection: Check the perfect condition of the sealing points.
Annually	Check the function of the display.
Every 2 years	Have an oil sample tested by a qualified oil laboratory. Observe the information in the following "Oil extraction" chapter for this.

Table 9: Inspection plan

To compare the current measured values of the device with the laboratory analysis, proceed as follows:

- ✓ According to the laboratory analysis, the gas concentration of hydrogen H₂ and carbon monoxide CO is at least 50 ppm.
 - ✓ According to the laboratory analysis, the moisture content H₂O is at least 5 ppm.
 - ✓ The ambient temperature is between -20 °C and 60 °C.
 - ✓ The oil temperature is between 10 °C and 90 °C.
1. Evaluation of the measured values only makes sense under these conditions.
 2. Compare the values of the laboratory analysis with the current measured values of the device.
 - ⇒ If the measuring accuracy complies with the information in the "Technical data" chapter, a field calibration is not required.
- ⇒ In the case of a deviation from the accuracy specified, proceed as described in the Field calibration [► Section 10.4, Page 68] chapter.

10 Maintenance

10.2 Maintenance

The maintenance message is intended to remind you, at regular intervals, to carry out the inspection and, if necessary, take an oil sample and perform a field calibration.

The maintenance information is shown on the display and can be issued via the event database of the MESSKO® MSET parameterization software or transmitted to a SCADA system via Modbus.

Event	Display	Recommended action
Maintenance in 6 months	Maintenance 6 months	Prepare inspection
Maintenance required	Maintenance required	Perform inspection with oil sample and field calibration

10.3 Oil extraction

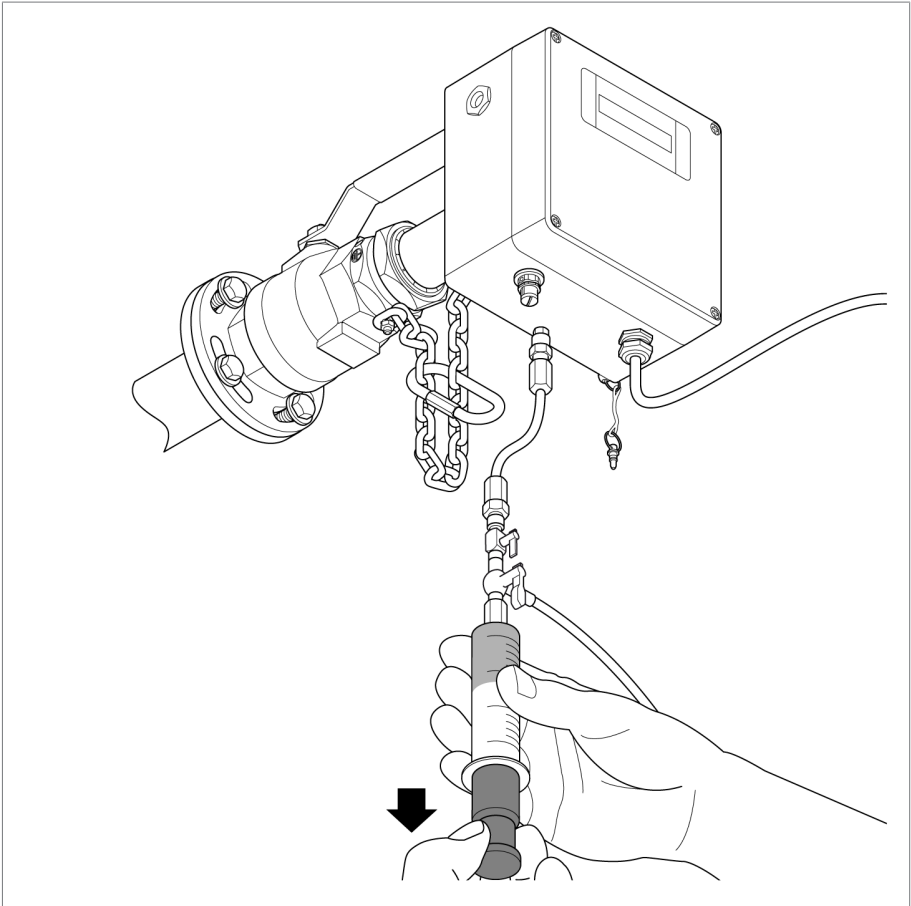

Figure 38: Oil extraction

Two sample extraction kits are necessary to extract an oil sample via the sample extraction connection. These are not included in the delivery and are to be purchased from a qualified oil laboratory. When performing the extraction, observe the accompanying operating instructions and the Adjusting the device chapter in these instructions.

Send the oil sample to an oil laboratory qualified for gas analyzers.

If the results of the analysis indicate that the device requires a field calibration, you can perform this with the MESSKO® MSET parameterization software.

10 Maintenance

10.4 Device field calibration

The field calibration of the device gas analysis values serves to ensure the correct measurement results:

- For aged insulating oils
- For modified oils (e.g., the addition of additives)
- For oils that do not satisfy the standards ASTM D3486-091, IEC 60296 or IEC 60422.

A field calibration should be performed if the following conditions apply:

Condition	CO	H ₂	H ₂ O
Deviation from laboratory values	>15% or 20 ppm *)	>10% or 20 ppm *)	>5 ppm
Laboratory value	>50 ppm	>50 ppm	>5 ppm

*) Evaluated in accordance with IEC 60567 – Appendix E

A field calibration of a gas component with lower laboratory values is not recommended.



The correct values for a field calibration can only be guaranteed if the oil is analyzed in a qualified oil laboratory for gas analyses.

10.4.1 Taking a sample for field calibration

The following material is required for taking a sample:

Included in the delivery:

- Sample extraction adapter

Not included in the delivery:

- Oil extraction kit with sample information sheet
- Oil waste container
- Cleaning cloths



Taking a sample for a field calibration is only recommended if the following conditions apply to the device:

Property	Condition
Oil temperature T_{oil}	$10\text{ °C} < T_{oil} < 90\text{ °C}$
Ambient temperature $T_{ambient}$	$-20\text{ °C} < T_{ambient} < 60\text{ °C}$

To take an oil sample, proceed as follows:

1. Complete the sample information sheet fully.
2. Take an oil sample in accordance with IEC 60567 and send it to the oil laboratory in suitable packaging. The sample analysis values will be used later for the field calibration.

10.4.2 Field calibration

Once the sample has been analyzed in the oil laboratory, you will be sent the oil sample report for the oil analysis. The following values are important:

- Hydrogen H_2
- Carbon monoxide CO
- Moisture content H_2O
- Date of the oil sample

Follow the recommendations laid out in the sample report.

10 Maintenance

To perform the field calibration, proceed as follows:

1. Connect the device to the PC using the USB service adapter and open the MESSKO® MSET parameterization software.

⇒ The parameterization software connects to the device.

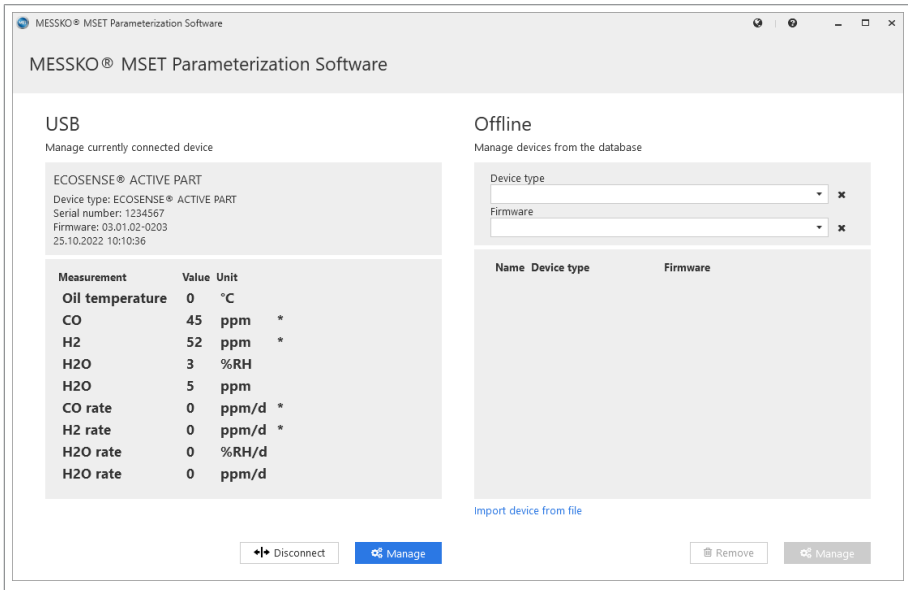

Figure 39: MSET main screen

2. Click on **Manage** on the left-hand side of the Home view (USB).

3. Click on **Service** and then on **Field calibration**.

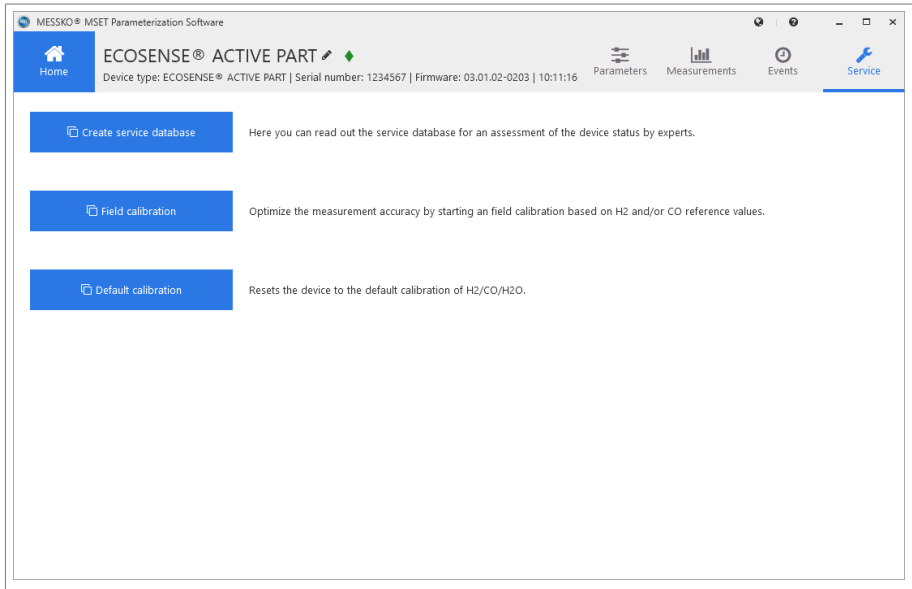

Figure 40: Service

4. Select the gases for which you want a field calibration. Enter the laboratory results as the reference corresponding to the respective gas.
 5. Enter the date of the oil sample from the laboratory results.
 6. Click on **Start** to initiate the field calibration.
 7. The progression of the process can be viewed in the status window. **NO-TICE!** The process may take several minutes.
 8. Wait until the status column displays whether or not the calibration is possible.
 9. If the calibration is possible, enter the password and initiate the transmission of the calibration data to the device via **Send calibration**.
 10. Wait until the result of the calibration is displayed in the status column.
 11. Upon successful calibration, you can close the window and disconnect the connection between the device and the laptop.
 12. Unscrew the USB service adapter.
 13. Then screw the protective cap onto the M12 socket to protect the device against water ingress.
- ⇒ The system will set itself to the adjusted level within the next 24 hours.

10 Maintenance



If you have made an incorrect entry, you can reset the parameters of the gas analysis (H_2 and CO) and the humidity (H_2O in ppm) to the default calibration. To do so, send a valid access authorization to the device via the MESSKO® MSET parameterization software under **Service** in the area **Default calibration** in accordance with the corresponding operating instructions.

10.5 Cleaning

When necessary, the installed device can be cleaned from the outside with water and a mild lye.

Only use a dry cleaning cloth to wipe down the measuring head of the uninstalled device (see chapter Design).

▲ CAUTION



Hot oil escape

Risk of injury and slipping.

- ▶ Wear safety clothing.
- ▶ Carry out the operating steps in the specified sequence.
- ▶ Ensure that the gate valve remains closed after the removal of the device.

▲ DANGER



Electric shock!

Risk of fatal injury due to electrical voltage. Always observe the following safety regulations when working in or on electrical equipment.

- ▶ Disconnect the system.
- ▶ Lock the system to prevent an unintentional restart.
- ▶ Ensure all poles are de-energized.
- ▶ Cover or cordon off adjacent energized parts.
- ▶ Disconnect electrical cabling correctly.

NOTICE

Damage to the device!

Electrostatic discharge can lead to damage to the device.

- ▶ Take precautionary measures to prevent the build-up of electrostatic charges on work surfaces and personnel.

11 Removal

11.1 Removing the device

1. Undo and remove the chain connector.

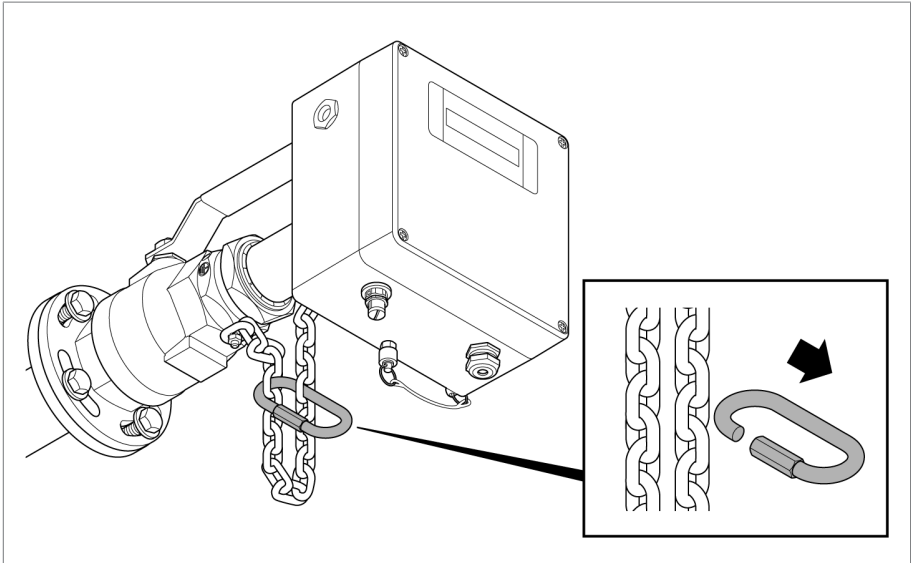

Figure 41: Releasing the chain

2. Release the ball valve clamp connection.

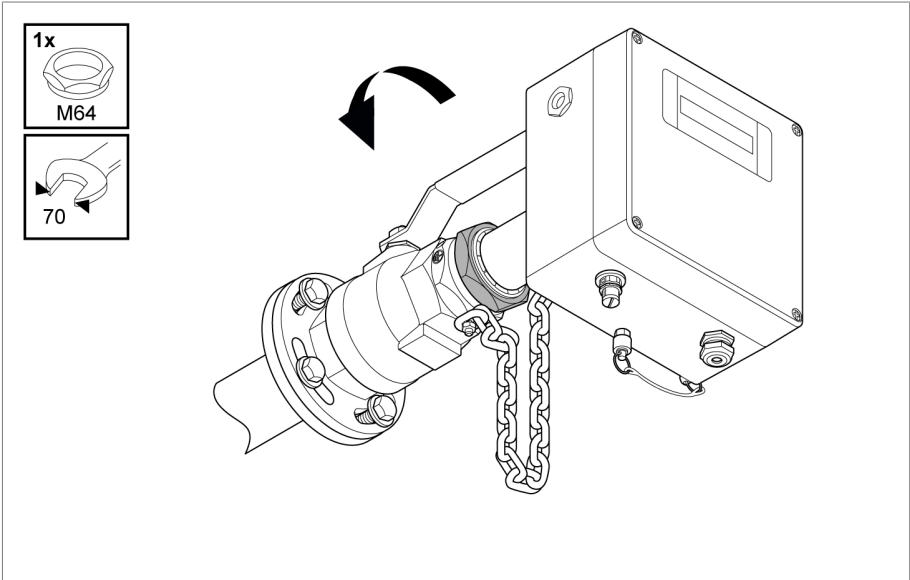

Figure 42: Releasing the ball valve clamp connection

3. Pull the device as far as possible out of the ball valve.



The chain should now be tightly tensioned.

11 Removal

NOTICE

Danger of damaging the measuring pipe!

If the device is operated in front of a slide valve, the tightly tensioned chain ensures that the measuring pipe of the device has been pulled out far enough and that the slide valve does not collide with it when closing.

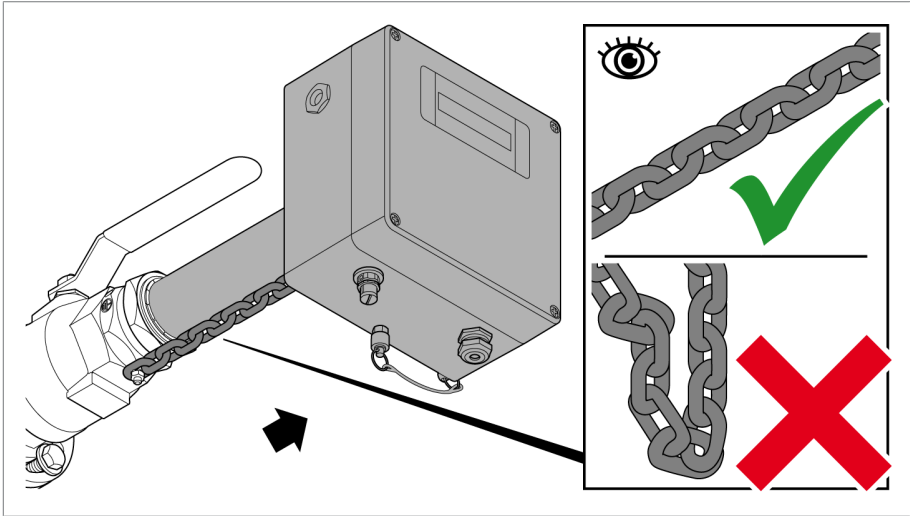

Figure 43: Pulling the device out

4. Close any upstream valves and slides.

5. Close the ball valve and position the oil collecting tray under the opening of the ball valve.

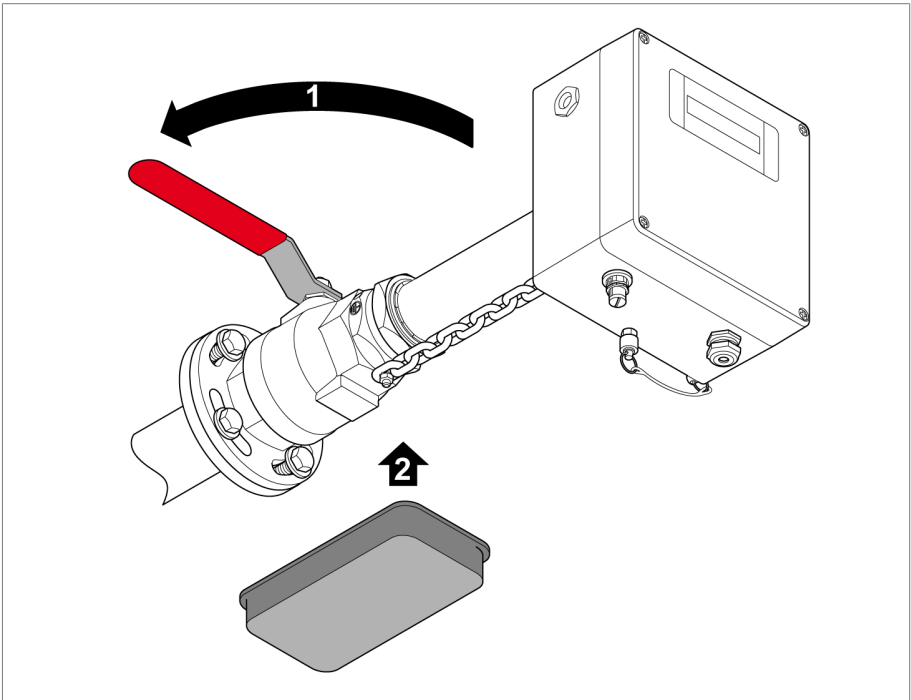

Figure 44: Closing the ball valve

⚠ CAUTION



Danger of crushing due to falling device

The device is now free. Protect yourself against spraying oil with personal protective equipment and support the weight of the device.

11 Removal

6. Unscrew the fixing screw for the safety chain on the device far enough to free the chain. Pull the safety chain out and screw the fixing screw back into place.

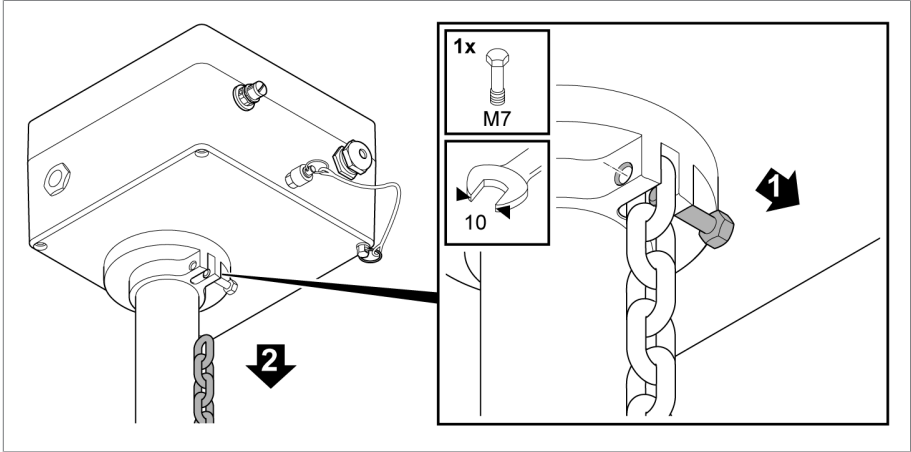

Figure 45: Releasing the link chain

7. Carefully pull the device out of the ball valve.

NOTICE

Type and source of danger

Ensure that the device does not become jammed during this procedure. Support the weight by hand. Collect the excess oil in the collecting tray.

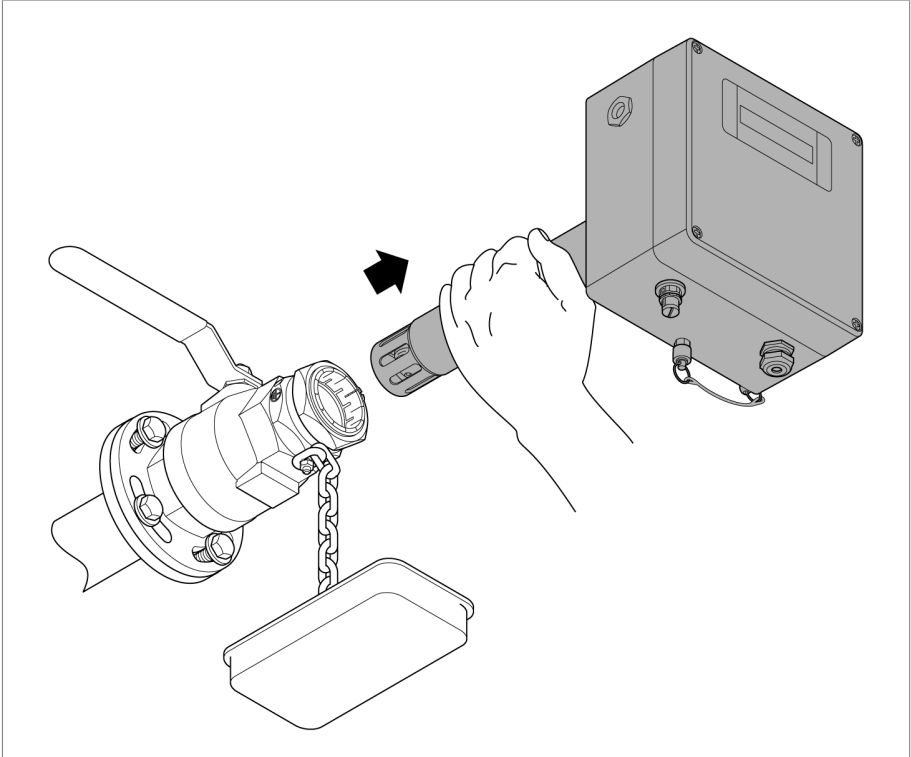

Figure 46: Pulling the device out of the ball valve

11 Removal

8. Set the device down securely on a scratch-resistant and non-slip level surface.

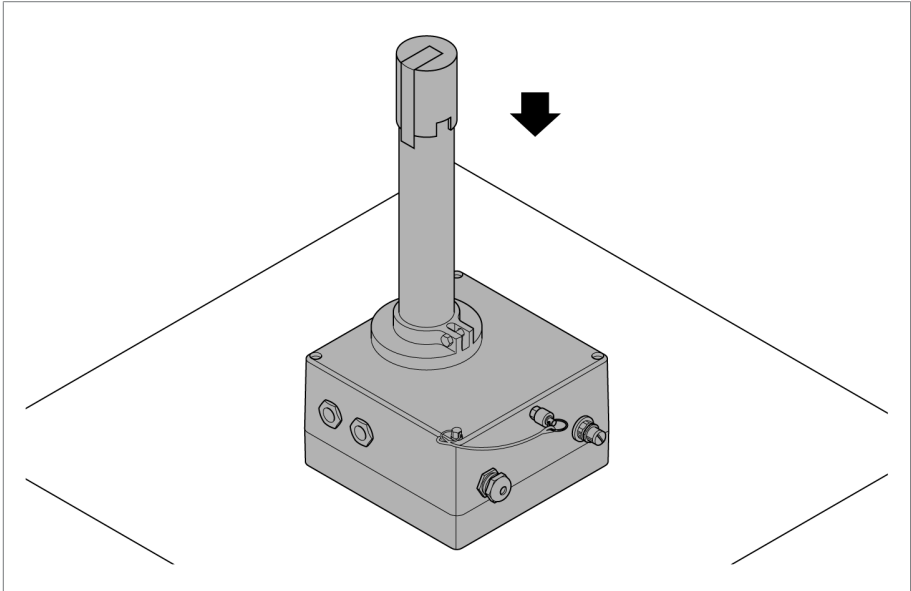

Figure 47: Setting the device down securely



When doing so, ensure that the display is not damaged.

- Place the supplied red protective cap onto the measuring pipe and close the protective cap opening with adhesive tape.

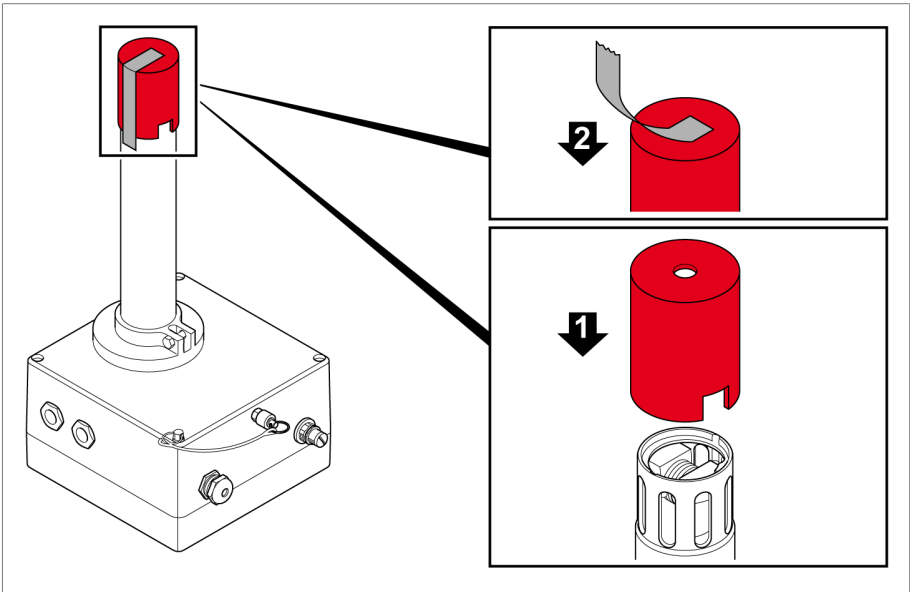

Figure 48: Positioning the protective cap

- Clean the device with a dry cloth.

The device has now been removed and can be transported or stored in suitable packaging.

The ball valve is then to be secured:

▲ CAUTION



Hot oil escape

Risk of injury and slipping.

- ▶ Ensure that the ball valve is closed.
- ▶ Wear safety clothing.

11 Removal

1. Open the air-vent valve of the ball valve dummy plug and insert the dummy plug into the ball valve up to the stop.

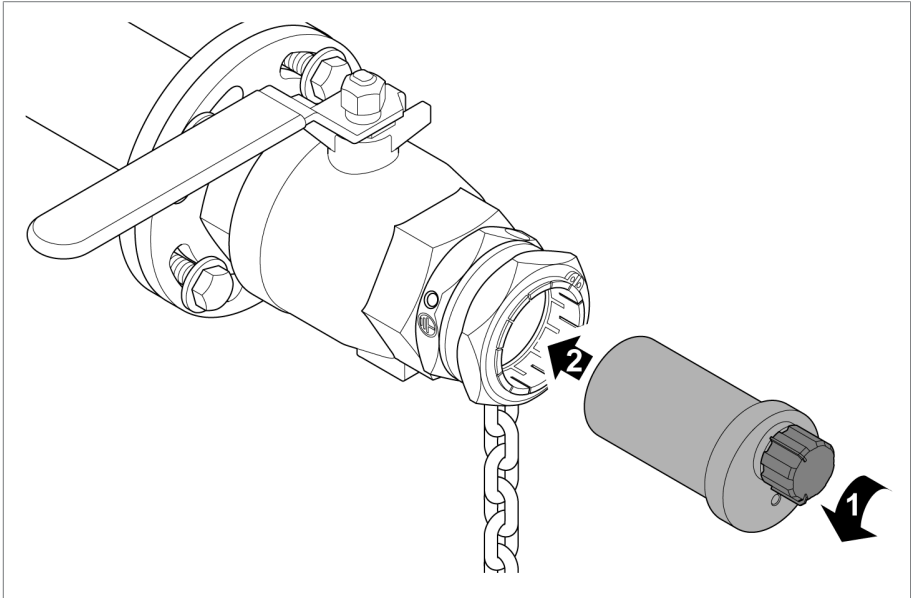

Figure 49: Insert the dummy plug into the ball valve.

2. Close the air-vent valve and tighten the ball valve clamp connection.

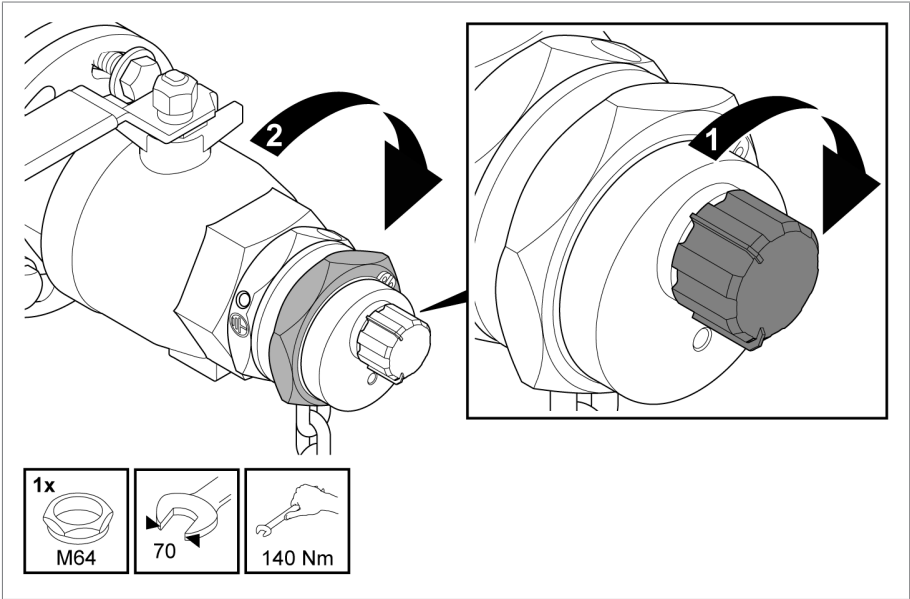

Figure 50: Tightening the ball valve clamp connection

3. Secure the free end of the safety chain with the dummy plug fixing screw.

11 Removal



Attach the chain under as much tension as possible.

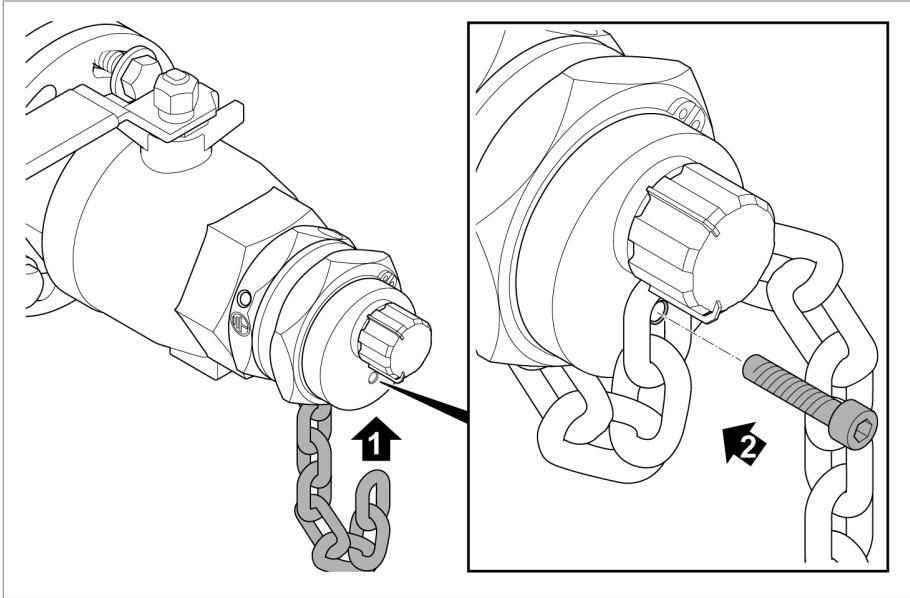

Figure 51: Securing the dummy plug with link chain

- Warning sign "Do not close!" remove the warning sign "Do not close!" on the slide valve.



Figure 52: Slide valve warning sign

Observe the national disposal regulations in the respective country of use.

13 Technical data

Measurement					
Application	Determination of the gas concentration of fault gases as well as moisture in oil and oil temperature of mineral-based transformer insulating oil in accordance with IEC 60296:2012 / ASTM D3487-09				
Measured variables	H ₂	CO	Humidity		Oil temperature
			Relative	Absolute	
Display in alternation					
Lower detection limit	15 ppm	25 ppm	3% RH	5 ppm	-20 °C
Upper detection limit	2,000 ppm	2,000 ppm	90% RH	2,000 ppm	+115 °C
Measuring accuracy	±15% ^{1,2} or ₃	±20% ^{1,2} or ₃	±1.8% RH ⁵	±2 % ⁴	±1 °C
Repetition accuracy	±5% ² or ³ ±10 ppm	±5% ² or ³ ±10 ppm	±1% RH	±1 % ⁴	±1 °C
Sensor resolution	1 ppm	1 ppm	1% RH	n. a.	1 °C

¹ Determination based on IEC 60567, Appendix E

² Of the measured value

³ Depending on which value is larger

⁴ Of the saturation curve; IEC 60422

⁵ At +23 °C

Conditions of use	
Locations of use	Indoors and outdoors, all climate zones
Installation altitude	Up to 4,000 m above sea level
Offshore	Optional
Mounting location	Directly on the transformer tank or in the oil closed circuit cooling pipe; installation horizontal
Ambient temperature in operation	-40...+60 °C
Oil temperature during operation, at the measuring point	-20...+115 °C
DGA measuring range with respect to the ambient temperature	-20...+50 °C

13 Technical data

Conditions of use

DGA measuring range with respect to the oil temperature at the measuring point	+10...+80 °C
Ambient humidity	0...100% RH
Ambient temperature, storage/transport	-40...+80°C

Device properties

Mechanical connection	Via ball valve and configurable flange DN50 or DN80; with safety chain for safe installation and removal
Measuring pipe length	Measuring pipe: 507 mm
Oil extraction connection	Luer lock socket on the device; adapter set for safe and clean oil extraction
Operation	VFD display (suitable for use in daylight) for displaying measured values and messages in alternation
Materials used	Stainless steel and aluminum; All external parts and parts in contact with oil are weather-resistant, resistant to transformer oil and UV-resistant
Color (terminal box)	RAL 7035
Vacuum resistance	5 Pa for 48 hours
Pressure resistance	Max. 400 kPa
Degree of protection	IP 66
Dimensions	657 x 218 x 264 mm
Device weight	Approx. 14 kg (without ball valve / flange / safety chain)
Ball valve weight	Approx. 6 kg (including flange and safety chain)

Electrical connection

Power supply	95...280 V AC, 50/60 Hz or 95...280 V DC (protected against polarity reversal)
Power consumption	<13 W
Overvoltage category	III
Connection terminals	Power supply
Cable gland	1 x M20 x 1.5; 8...15 mm lead diameter

13 Technical data

Interfaces	
Service interface	5-pole socket (Molex) for communication via Modbus RTU and parameterization via MSET parameterization software
MESSKO® MSET parameterization software	
Download	<ol style="list-style-type: none">1. Register for download in the customer portal: https://portal.reinhausen.com.2. Create your ECOSENSE® ACTIVE PART under myEquipment > Components.3. Then enter the serial number under mySelfServices > Software updates.
Operating system	Microsoft Windows 10 or later
Measured value display and evaluation	Display of the current measured values and device information; Event database with time stamp (date and time); Graphic display and evaluation of the temporal progression of the measured values; Export of the measured values (CSV format) or protocol settings (PDF format)
Parameterization	Configuration of the parameters for commissioning, communication and ongoing operation
Field calibration	Setting the time stamp of the oil sample extraction; Entry of the reference values in accordance with the laboratory report
Service	Reading out the internal device service database for further analysis by Service experts
Mechanical tests	
Vibration	10–150 Hz with 2g, 2 h (IEC 60068-2-6)
Seismic events	2–10 Hz, 22.5 mm, 1 h (IEC 60068-2-57)
Shock	10g, 10 ms (IEC 60068-2-27)

You will find the dimensional drawings and the drawing for the electrical connection on the following pages.

MASCHINENFABRIK REINHAUSEN GMBH COPYRIGHT RESERVED
 THE REPRODUCTION, DISTRIBUTION AND UTILIZATION OF THIS DOCUMENT AS WELL AS THE COMMUNICATION OF ITS CONTENTS TO OTHERS WITHOUT EXPRESS AUTHORIZATION IS
 PROHIBITED. OFFENDERS WILL BE HELD LIABLE FOR THE PAYMENT OF DAMAGES. ALL RIGHTS RESERVED IN THE EVENT OF A PATENT, UTILITY MODEL OR DESIGN.

DATE	NAME	DOCUMENT NO.
11.08.2022	THIELEK	SED 8947473 000 00
CHKD. 11.08.2022	REHNELT	CHANGE NO.
SCALE	KLEYN	1116752
STAND. 11.08.2022		12

DIMENSION
 IN mm
 EXCEPT AS
 NOTED



TRANSFORMER ACCESSORIES
 ECOSENSE ACTIVE PART
 Maßzeichnung/DIMENSION DRAWING

SERIAL NUMBER

MATERIAL NUMBER
 101719160M

SHEET
 1 / 3

1:5

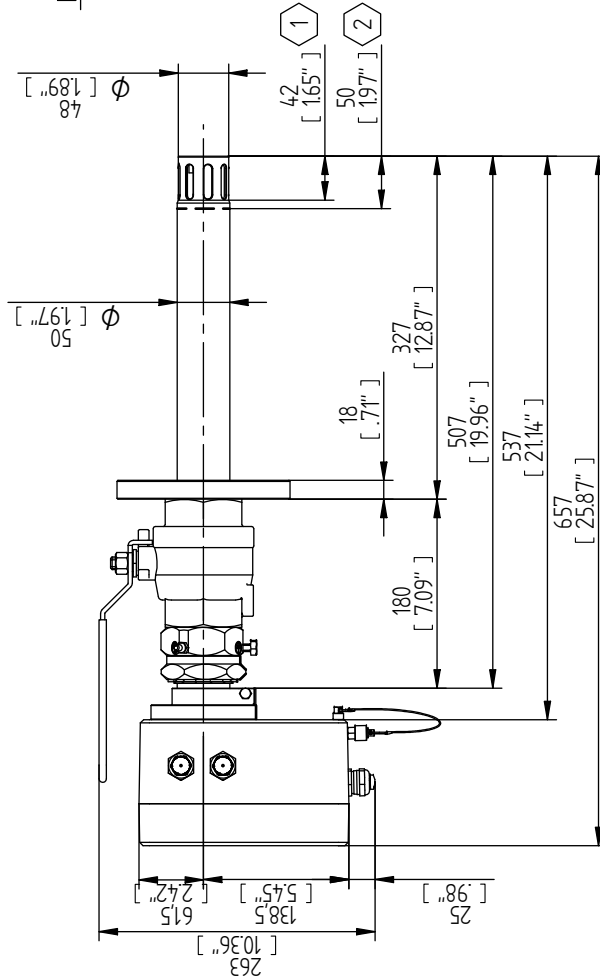

3 Flanschrichtung wie dargestellt / FLANGE ALIGNMENT AS SHOWN

2 empfohlene Eintauchtiefe / RECOMMEND MOUNTING DEPTH

1 Mindesteintauchtiefe / MINIMUM MOUNTING DEPTH

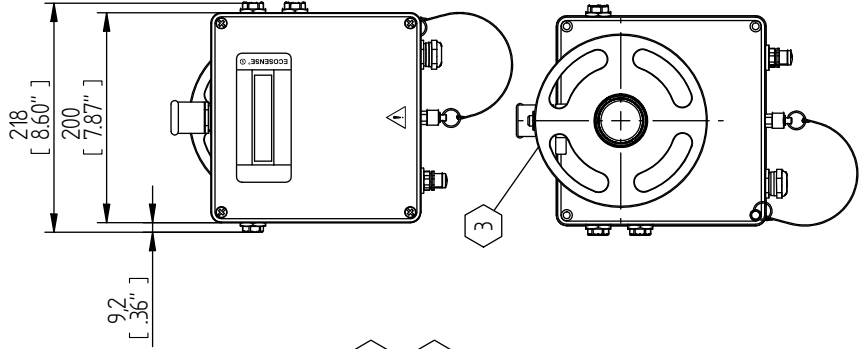

MASCHINENFABRIK REINHAUSEN GMBH COPYRIGHT RESERVED
 THE REPRODUCTION, DISTRIBUTION AND UTILIZATION OF THIS DOCUMENT AS WELL AS THE COMMUNICATION OF ITS CONTENTS TO OTHERS WITHOUT EXPRESS AUTHORIZATION IS
 PROHIBITED. OFFENDERS WILL BE HELD LIABLE FOR THE PAYMENT OF DAMAGES. ALL RIGHTS RESERVED IN THE EVENT OF THE GRANT OF A PATENT, UTILITY MODEL OR DESIGN.

DATE	NAME	DOCUMENT NO.
11.08.2022	THIELEK	SED 8947473 000 00
11.08.2022	REHNELT	CHANGE NO. SCALE
11.08.2022	KLEYN	1116752 12

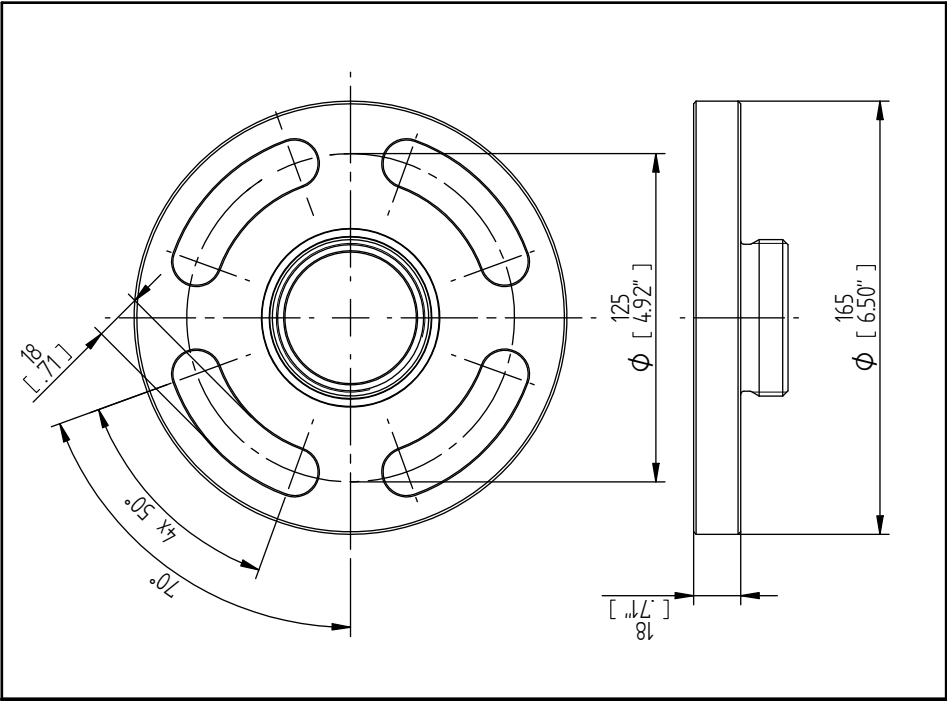
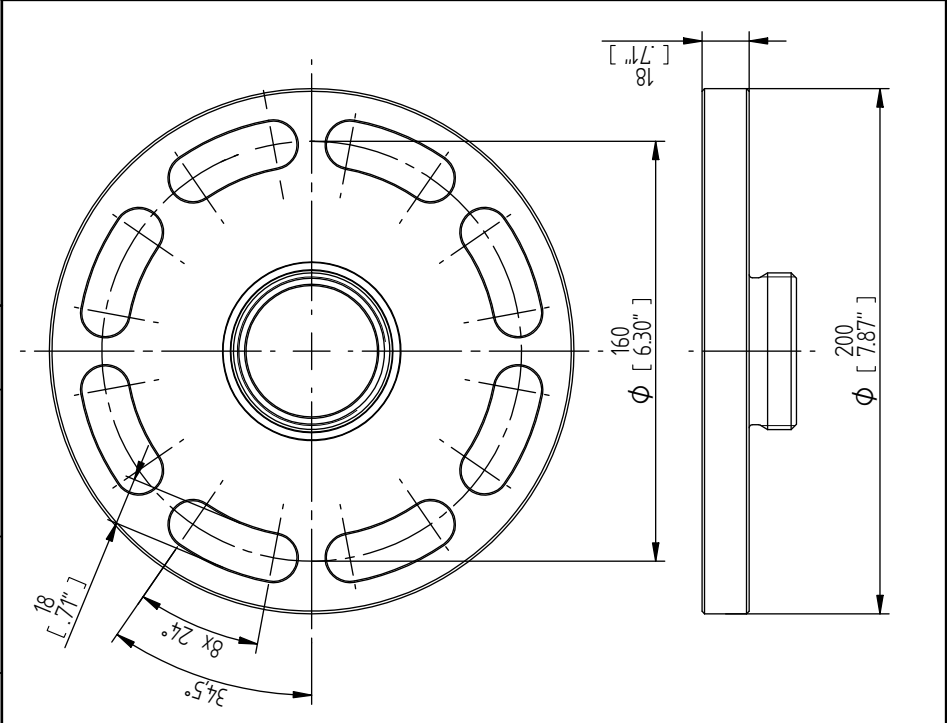

DIMENSION
 IN mm
 EXCEPT AS
 NOTED



TRANSFORMER ACCESSORIES
 ECOSENSE ACTIVE PART
 Maßzeichnung/DIMENSION DRAWING

SERIAL NUMBER -	
MATERIAL NUMBER 101719160M	SHEET 2 / 3

DATE	NAME	DOCUMENT NO.
DFTR: 11.08.2022	THIELEK	SED 8947473.000.00
CHKD: 11.08.2022	REHNELT	CHANGE NO. SCALE
STAND: 11.08.2022	KLEYN	1116752 12

DIMENSION
IN mm
EXCEPT AS
NOTED



TRANSFORMER ACCESSORIES
ECOSENSE ACTIVE PART
Maßzeichnung/DIMENSION DRAWING

SERIAL NUMBER

MATERIAL NUMBER
101719160M

SHEET
3 / 3

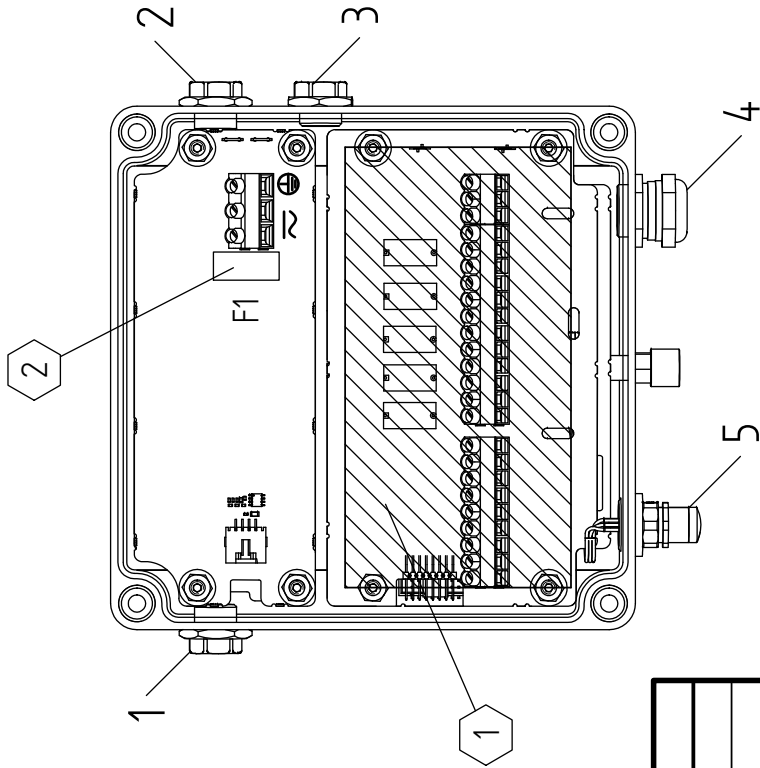

1 ohne Funktion / WITHOUT FUNCTION

2 Schmelzsicherung / INERT FUSE: 500 V, 500 mA

Pos./POS.	Beschreibung/DESCRIPTION
1	Belüftung / VENTILATION
2	Belüftung / VENTILATION
3	Belüftung / VENTILATION
4	Kabelverschraubung / CABLE GLAND: M20x1,5
5	Schnittstelle / INTERFACE: M12x1 MODBUS RTU

15.1 Data point table for Modbus RTU

Separate input register

No.	Address	Size	Description	Designation
1	0	1 byte	On / Off	CO limit 1
2	1	1 byte	On / Off	CO limit 2
3	2	1 byte	On / Off	H ₂ limit 1
4	3	1 byte	On / Off	H ₂ limit 2
5	4	1 byte	On / Off	H ₂ O limit 1
6	5	1 byte	On / Off	H ₂ O limit 2
7	6	1 byte	On / Off	CO rate limit 1
8	7	1 byte	On / Off	CO rate limit 2
9	8	1 byte	On / Off	H ₂ rate limit 1
10	9	1 byte	On / Off	H ₂ rate limit 2
11	10	1 byte	On / Off	H ₂ O rate limit 1
12	11	1 byte	On / Off	H ₂ O rate limit 2
13	12	1 byte	On / Off	Maintenance in 6 months
14	13	1 byte	On / Off	Maintenance required
15	14	1 byte	On / Off	CO Value Valid ¹⁾
16	15	1 byte	On / Off	H ₂ Value Valid ¹⁾
17	16	1 byte	On / Off	H ₂ O Value Valid ¹⁾
18	17	1 byte	On / Off	H ₂ O Mode %RH

¹⁾ If the "Value Valid = Off" status is present, it means the same as an asterisk (*) in the display or in the MSET status display, and the system is outside the specified measuring range in accordance with the "Technical data" chapter. The following applies to the transmitted measured value:

- During the first measurement after the running-in phase, the value of the lower detection limit is transmitted.
- If measured values within the specified measuring range have already been recorded, then the last valid measured value is transmitted.

If the status changes to "Value Valid = On", then the system is back in the valid measuring range.

15 Appendix

Input register

No.	Address (dec.)	Size	Description	Designation
1	0	4 bytes, SFLOAT	None	CO value ppm
2	2	4 bytes, SFLOAT	None	H ₂ Value ppm
3	4	4 bytes, SFLOAT	None	H ₂ O Value ppm
4	6	4 bytes, SFLOAT	None	Oil Temperature
5	8	4 bytes, SFLOAT	-	Empty 2
6	10	4 bytes, SFLOAT	None	H ₂ O %RH
7	12	4 bytes, SFLOAT	-	Empty 4
8	14	4 bytes, SFLOAT	None	H ₂ O Rate %RH/d
9	16	4 bytes, SFLOAT	None	CO Rate ppm/d
10	18	4 bytes, SFLOAT	None	H ₂ Rate ppm/d
11	20	4 bytes, SFLOAT	None	H ₂ O Rate ppm/d

Maschinenfabrik Reinhausen GmbH

Falkensteinstrasse 8
93059 Regensburg

☎ +49 (0)941 4090-0

✉ sales@reinhausen.com

www.reinhausen.com

8969216/00 EN - ECOSENSE® ACTIVE PART -
F0410600 (SET) - 12/22 - Maschinenfabrik Reinhausen GmbH 2022

THE POWER BEHIND POWER.

